

Changes for the Better

Mitsubishi iQ Platform-compatible
Graphic Operation Terminal
GOT1000 Series [GT12 Model]

October 2009 **New Product Release**

GRAPHIC OPERATION TERMINAL
GOT1000

GT12 Debut!



10.4
inch



8.4
inch

Cost Effective **Large-Size** **Built-in Ethernet**

**Large-size models with built-in Ethernet
in the standard model range!**

GOT1000 Comprehensive Lineup

Including the new, cost-effective GT12 Series models, a total of 73 models provides the widest range of display options for the OEM machine builder and End User facility installation.

Screen Size	Full-spec Model		Standard Model	Standard Model	Compact Model	
	With a variety of integrated functions, such as Ethernet and multimedia		Wide range of uses from network to stand alone	Standard functions with built-in Ethernet	Enhanced with basic functions for stand alone application	Including all the basic functions required for a HMI display
15"	GT16 GT1695M-XTBA GT1695M-XTBD	GT15 GT1595-XTBA GT1595-XTBD				
12.1"	GT1685M-STBA GT1685M-STBD	GT1585V-STBA GT1585V-STBD GT1585-STBA GT1585-STBD				
10.4"	GT1675M-STBA GT1675M-STBD GT1675M-VTBA GT1675M-VTBD	GT1575V-STBA GT1575V-STBD GT1575-STBA GT1575-STBD GT1575-VTBA GT1575-VTBD	GT12 GT1275-VNBA NEW	10.4" type	GT1265-VNBA AC type Resolution: 640x480 Display colors: 256 colors LCD: TFT color LCD Safety standard : CE, UL 8.4" type	
8.4"	GT1665M-STBA GT1665M-STBD GT1665M-VTBA GT1665M-VTBD	GT1565-VTBA GT1565-VTBD GT1562-VNBA GT1562-VNBD	GT1265-VNBA NEW			
5.7"		GT1555-VTBD GT1555-QTBD GT1555-QSBD GT1550-QLBD				
4.7"						
4.5"						
3.7"						
	Multimedia Built-in Memory Built-in Interface	Multimedia Video/RGB 15MB Ethernet USB host USB device RS-232 RS-422/485	Video/RGB 5-9MB USB device RS-232	6MB Ethernet USB device RS-232 RS-422/485	3MB USB device RS-232	512KB-3MB RS-232
	Built-in Interface <small>*Depends on the model or hardware version</small> Optional Interface	Bus RS-232 RS-422 RS-422/485 CC-Link IE CC-Link (ID station/via G4) MELSECNET/H	Ethernet Bus RS-232 RS-422 RS-422/485 CC-Link IE CC-Link (ID station/via G4) MELSECNET/H	Bus RS-422 RS-422/232 RS-422/485 CC-Link (via G4 only)	Bus RS-422 RS-422/232 RS-422/485 CC-Link (via G4 only)	Bus RS-422 RS-422/232 RS-422/485 CC-Link (via G4 only)

NEW model
GOT1000 GRAPHIC OPERATION TERMINAL

GT12 **NEW**

Fully integrated models now released!

GT12 10.4 inch and 8.4 inch models

Integrated hardware and functionality is now available in large-size models.

Stylish body

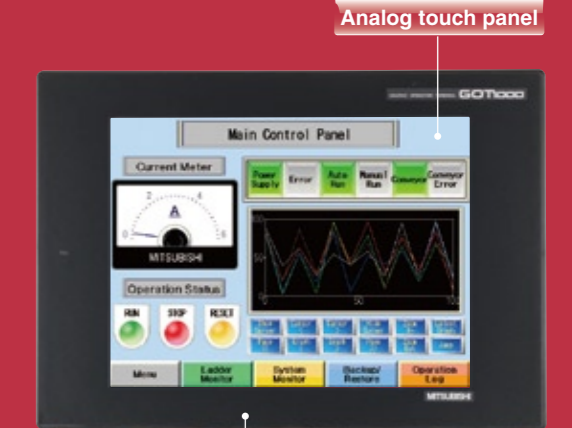

Analog touch panel

Full flat face

Flexible embedded communications

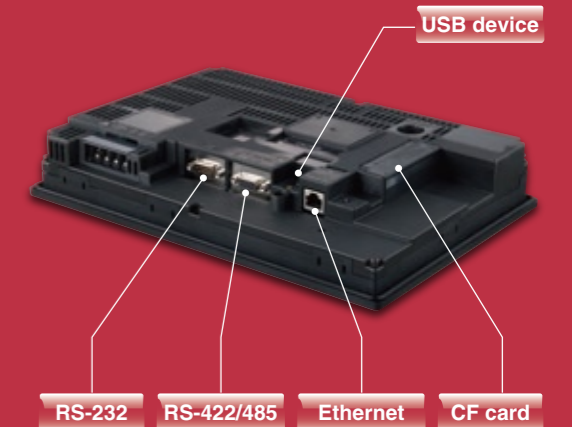

USB device

RS-232 RS-422/485 Ethernet CF card

* For more details about connection destination of models other than the GT12 series, see "GOT1000 series catalog" <L(NA) 08054-E 0901>.

GT12, new models offer flexible configurations and expandability

A wide range of devices can be interfaced to GT12 models using Ethernet • RS-232 • RS-422/485

A variety of built-in interfaces

The built-in interfaces (Ethernet, RS-422/485 and RS-232) enable connection to up to two kinds of FA equipment simultaneously.

Ethernet helps extend systems

The built-in Ethernet interface connects to PLC CPUs with built-in Ethernet and host systems easily.

Wide selection of connectable FA devices and peripherals

- Mitsubishi PLCs/motion controllers
- Mitsubishi servo amplifiers
- Mitsubishi inverters
- Mitsubishi industrial robots
- Mitsubishi CNCs
- Microcomputers
- Temperature controllers
- Barcode readers
- RFID readers
- Third party PLCs

*: For the connectable models and connection types, refer to GOT1000 series connection manuals.

Connection type to Mitsubishi PLCs/motion controllers

Connection type	Mitsubishi PLCs/motion controllers			
	Ethernet	CPU direct connection	Computer link	CC-Link (via G4)
MELSEC-Q series (Q mode)	○*1	○*2	○	○
MELSEC-Q series (A mode)	○	○	○	—
MELSEC-QnA series	○	○	○	—
MELSEC-A series	○	○	○	—
MELSEC-FX series	○	○	—	—
Motion Controller CPU (Q series)	—	○	○	○
Motion Controller CPU (A series)	—	○	○	—

*1: QnUDE has a built-in Ethernet module; additional module is not required
*2: Excluding QnUDE

Multi-channel function

The multi-channel function enables the connection of different types of FA devices simultaneously.

Up to 2 channels of equipment such as PLCs/servo amplifiers/inverters/temperature controllers can be connected and monitored.

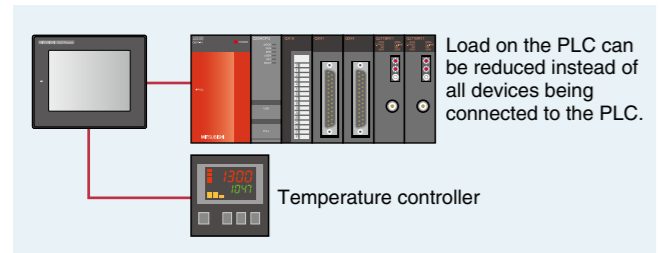

Other features

USB device (Mini-B, rear face)

Connecting to a personal computer via USB (Mini-B) enables the transfer of operating systems and project data. The FA transparent function enables modification of sequence programs.

TFT LCD VGA (640x480) monitor

TFT LCD display provides easily-viewable screens. VGA resolution provides satisfactory expressiveness.

Analog touch panel

Objects such as push buttons and switches can be freely placed around the screen. The clear display face without grids makes it easy to recognize pictures and characters.

Multi-terminal connection

Up to two GT12 units can be connected to one PLC

When RS-422 is used to connect the 1st GOT *1

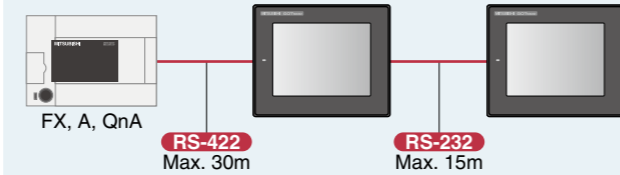

When RS-232 is used to connect the 1st GOT *1

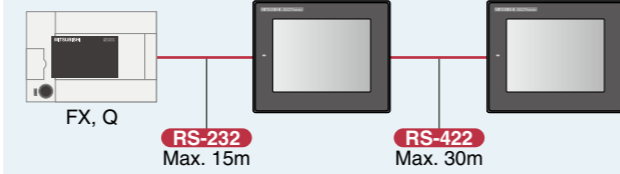

*1: Refer to the connection manual for applicable models, required interface and compatibility with serial communication units (computer link units). The maximum length varies depending on the connected equipment. Refer to the connection manual for more details.

Multi-drop connection

Coming soon

Multiple GT12 units can be connected to one PLC unit via the serial multi-drop connection unit.

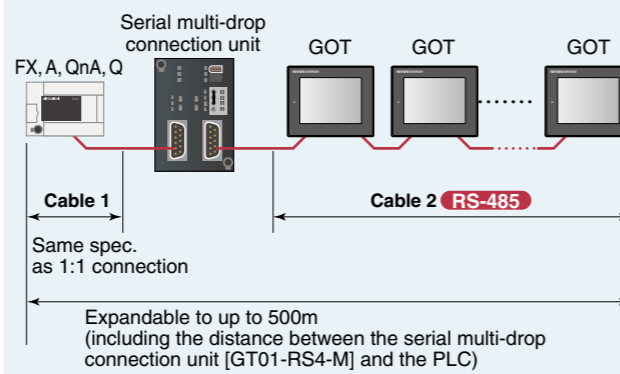

Ample memory capacity

The GT12 has 6MB memory so users can add a variety of objects, parts, and functions without running out of memory.

GT12	6MB
GT11	3MB
GT105□/GT104□	3MB
GT1030	1.5MB
GT1020	512KB

GT12 provides many essential functions suited for engineered solutions

Useful functions of GT12

Even low cost models are infused with functionality commonly found in more expensive models.

- Multi-channel function
- Logging function
- Historical trend graph function
- Backup/restore function
- Recipe function (CSV, binary)
- Advanced alarm function
- A/FX list editor
- System monitor function

Multi-language display (excluding KANJI region settings)

Logging function/Historical trend graph

Logging function

Collecting data from temperature controllers and other units with the GOT can reduce the load on the PLC.

Collected data can be used for archives and analytical purposes when being saved to a CF card.

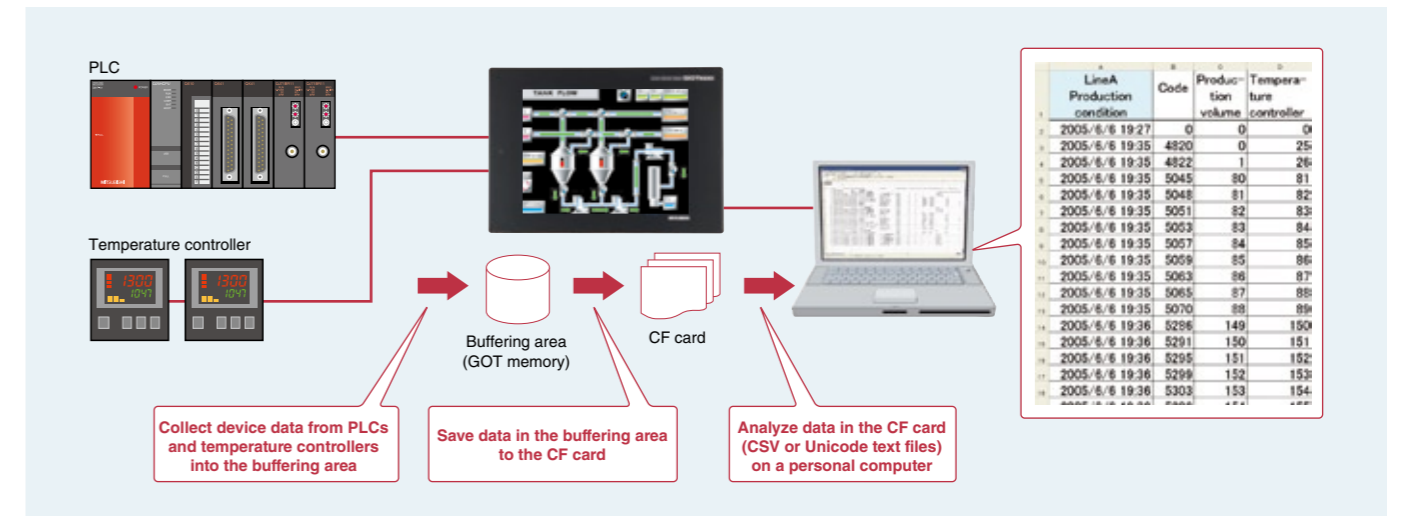

Historical trend graph

Data collected by the logging function can be displayed in a time-series graph from a CF card as well as from the buffering area.

The data collected by the logging function can be displayed in graph form; past data can be displayed simply by touching a scroll switch.

*: Logging function settings are required to use historical trend graph.

By specifying a date and time, a specific time can be displayed in the center of the graph.

Backup/restore function

Backup important sequence programs to be safe and secure in case of an emergency

- The sequence program and parameter data of the PLC CPU and motion controller can be backed up to the CF card in the GOT.
- Users can perform batch operation to restore the data to the PLC CPU or motion controller.

<Applicable data> Programs, parameters, device comments, device initial value data, file registers, etc.

<Applicable model> MELSEC Q-Series (excluding Q12PRH/Q25PRHCPU), Q-Series motion controllers (SV13/SV22 only), MELSEC FX-Series, CNC C70

<Applicable connection type> CPU direct connection, computer link connection, Ethernet connection (host only)

<Optional device> CF card

PLC CPU programs can be changed easily without a personal computer at the worksite or any previous programming knowledge of GX Developer.

For more details, see "GOT1000 series catalog" <L(NA) 08054-E 0901>.

Example of use

Make a data backup in preparation for PLC CPU failure or a dead battery to quickly replace the faulty device and restore the system using the backup.

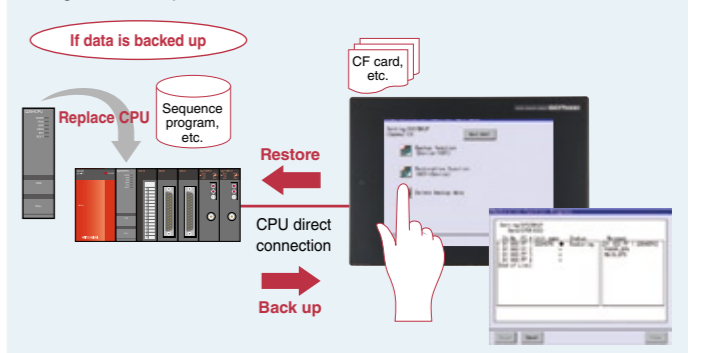

*: When replacing the PLC CPU, the restoration function may not be available depending on the system configuration and connection type.

General specifications

Item	Specification							
Operating ambient temperature	Display 0 to 50°C							
	Other than display 0 to 55°C							
Storage ambient temperature	-20°C to 60°C							
Operating ambient humidity	10 to 90% RH, no condensation							
Storage ambient humidity	10 to 90% RH, no condensation							
Vibration resistance	Conforming to JIS B 3502 and IEC 61131-2							
	Frequency	5 to 9 Hz	Acceleration	9.8 m/s ²	Half amplitude	3.5 mm	Sweep count	10 times in each of X, Y and Z directions
	Under intermittent vibration	9 to 150 Hz	9.8 m/s ²	—	—	—	—	
	Under continuous vibration	5 to 9 Hz	—	1.75 mm	—	—	—	
	9 to 150 Hz	4.9 m/s ²	—	—	—	—		
Impact resistance	Conforming to JIS B 3502 and IEC 61131-2 (147 m/s ² , 3 times in each of X, Y and Z directions)							
Operating atmosphere	No corrosive gas							
Operating altitude ¹	2,000 m or lower							
Installation location	In control panel							
Overvoltage category ²	II or lower							
Contamination level ³	2 or less							
Cooling method	Self-cooling							
Grounding	Class D grounding (100 Ω or less). Connect to panel if unable to ground.							

¹: Do not operate or store the GOT unit in pressurized environments where the pressure exceeds the 0 m elevation atmospheric pressure, as this could result in abnormal operation.

²: Assuming that the device is connected at some point between a public power distribution network and local system equipment. Category II applies to devices that are supplied with power from fixed equipment. The surge withstand voltage is 2,500 V for devices with ratings up to 300 V.

³: Index that indicates the level of foreign conductive matter in the operating environment of device. Contamination level 2 denotes contamination by non-conductive matter only, though momentary conductivity may occur due to occasional condensation.

Do not use or store the GOT under direct sunlight or in an environment with excessively high temperature, dust, humidity or vibration.

Performance specifications

Item	Specification	
	GT1275-VNBA	GT1265-VNBA
Display ¹	Type	TFT color LCD
	Screen size	10.4"
	Resolution	640 x 480 [dots]
	Display size	211.2(W) x 158.4(H) [mm]
	Number of displayed characters	16-dot standard font: 40 chars. x 30 lines (2-byte) 12-dot standard font: 53 chars. x 40 lines (2-byte)
	Display colors	256 colors
	View angle ²	Right/left: 45°, Up/down: 20°
	Intensity	200 [cd/m ²]
	Intensity adjustment	4-step adjustment
	Life	Approx. 52,000 hours (Operating ambient temperature: 25°C)
Backlight		Cold-cathode fluorescent tube (replaceable), 1 CCFL light.
	Life ³	50,000 hours or more (Time for display intensity reaches 50% at operating ambient temperature of 25°C)
Touch panel	Type	Analog resistive type
	Key size	Min. 2 x 2 [dots] (per key)
	No. of simultaneous touch points	Simultaneous touch prohibited ⁴ (1 point touch only)
Memory ⁵	Life	1,000,000 times or more (operating force 0.98 [N] or less)
	C drive	6 MB built-in flash memory (for saving project data and function OS)
	Life (No. of writings)	100,000 times
	Built-in SRAM	512KB

¹: On LCD screens, bright dots (permanently lit) and black dots (not to be lit) generally appear. Because the large number of display elements exist on an LCD screen, it is not possible to reduce appearance of the bright and black dots to zero. Flickering may occur depending on the display colors. Note that the existence of bright and black dots is a standard characteristic of LCD screens, and it does not mean that the products are defective or damaged.

²: LC panels have characteristics of tone reversal. Note that even within the indicated view angles, the screen display may not be clear enough depending on the display color.

³: Using the GOT screen save/backlight OFF functions prevents screen burn-in and extends the backlight life.

Component names

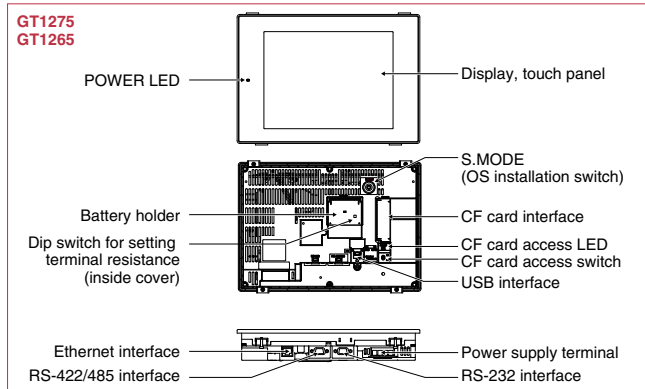

Product lineup

Model	Screen size [Resolution]	Display	Display color	Power supply	Memory capacity	
GT12	GT1275-VNBA	10.4" VGA[640x480 dots]	TFT color LCD	256 colors	100 to 240 V AC	6MB
	GT1265-VNBA	8.4" VGA[640x480 dots]	TFT color LCD	256 colors	100 to 240 V AC	6MB

Power supply specifications

Item	Specification
	GTT265/75-VNBA
Input power supply voltage	100 to 240 V AC (+10%, -15%)
Input frequency	50/60Hz ±5%
Input maximum voltampere	44 VA (at max. load)
Power consumption	18 W or less
With backlight off	15 W or less
Inrush current	40 A or less (4 ms, at max. load)
Permissible instantaneous failure time	Within 20 ms (100 V AC or more)
Noise resistance	Noise voltage 1,500 Vp-p, and noise width 1 μs, by noise simulator with noise frequency 25 to 60 Hz
Withstand voltage	1,500 V AC for 1 minute between power supply terminals and ground
Insulation resistance	10 MΩ or higher with an insulation resistance tester (500 V DC between power supply terminals and ground)
Applicable wire size	0.75 to 2 [mm ²]
Clamp terminal	Clamp terminals for M3 screw RAV1.25-3, V2-S3.3, V2-N3A and FV2-N3A
Tightening torque (terminal block's terminal screws)	0.5 to 0.8 [N·m]

Item	Specification	
	GT1275-VNBA	GT1265-VNBA
Battery		GT11-50BAT type lithium battery
	Backed up data	Clock data, alarm history, and recipe data
	Life	Approx. 5 years (operating ambient temperature: 25°C)
Built-in interface	RS-232	RS-232, 1 ch, Transmission speed: 115,200/57,600/38,400/19,200/9,600/4,800 bps, Connector shape: D-sub 9-pin (male), Application: communication with PLC and other FA devices, communication with personal computer ⁶
	RS-422/485	RS-422/485, 1 ch, Transmission speed: 115,200/57,600/38,400/19,200/9,600/4,800 bps, Connector shape: D-sub 9-pin (female), Application: communication with PLC and other FA devices
	Ethernet	Data transmission system: 100BASE-TX, 1 ch, Connector shape: RJ-45 (modular connector), Application: communication with connected devices
	USB	USB (Full Speed 12 Mbps), device 1 ch, Connector shape: Mini-B, Application: connection to personal computer (Project data upload/download, OS installation, FA transparent function)
	CF card	Compact flash slot 1ch., Connector shape: Type I, Application: data transfer, data storage
Buzzer output		Single tone (tone length adjustable)
Protective construction		JEM1030, Front: IP67 ⁷
External dimensions	303(W) x 214(H) x 53(D)	241(W) x 190(H) x 58(D)
Panel cut dimensions	289(W) x 200(H) mm	227(W) x 176(H) mm
Weight (excluding mounting brackets)	2.3kg	1.7kg
Applicable software packages	Screen design software	GT Designer3 Version 1.01B or later ⁷

⁴: An analog resistive touch display is used. When 2 points on the screen are touched simultaneously, if a switch is located the middle of the 2 points then the switch will be activated. Therefore, avoid touching 2 points on the screen simultaneously.

⁵: The memory is a ROM that permits overwriting of new data without having to delete the existing data.

⁶: This does not guarantee protection in all users' environments. The unit may not be used in an environment where it is exposed to splashing oil or chemicals for a long time or it is soaked with full of oil mist.

⁷: I/O Works will be supported in the next version (except for GT12).

External dimensions

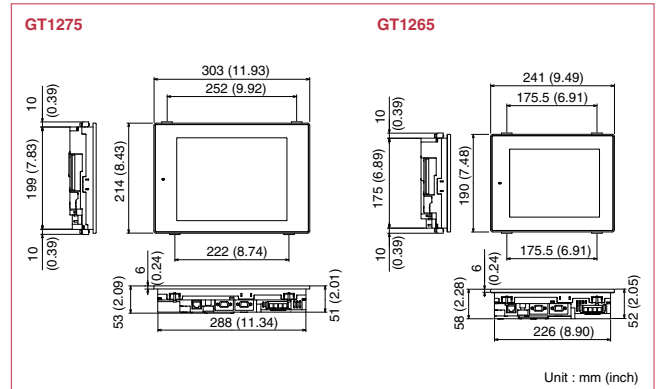

Options

Product name	Model	Specifications
Battery	GT11-50BAT	Battery for backup of clock data, alarm history, and recipe data (for replacement)
	GT11-70PSCB	Protective sheet for 10.4"
Protective sheet	GT11-60PSCB	Protective sheet for 8.4"
	GT12-70VLTN	Backlight for GT1275-VNBA
Backlight	GT12-60VLTN	Backlight for GT1265-VNBA

MITSUBISHI ELECTRIC CORPORATION

HEAD OFFICE: TOKYO BUILDING, 2-7-3 MARUNOUCHI, CHIYODA-KU, TOKYO 100-8310, JAPAN
 NAGOYA WORKS: 1-14, YADA-MINAMI 5, HIGASHI-KU, NAGOYA, JAPAN

USA	+1-847-478-2100	France	+33-1-55685568	Taiwan	+886-2-2299-2499
Brazil	+55-11-3146-2202	Poland	+48-12-630-47-00	Korea	+82-2-3660-9605
Germany	+49-2102-486-0	Czech Republic	+420-251-551-470	Singapore	+65-6470-2480
UK	+44-1707-278990	Russia	+7-812-633-3497	Thailand	+66-2-517-1328
Italy	+39-39-60531	South Africa	+27-11-928-2000	Indonesia	+62-21-6330833
Spain	+34-93-565-3131	China	+86-21-2308-2862	India	+91-124-4630300
				Australia	+61-2-9684-7777

When exported from Japan, this manual does not require application to the Ministry of International Trade and Industry for service transaction permission.

New publication, effective October 2009
 Specifications subject to change without notice.