

APLIQUE INDUSTRIAL ESTANCO – VKS 100CG

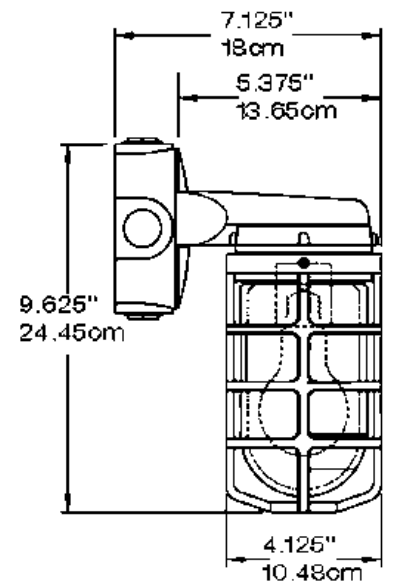
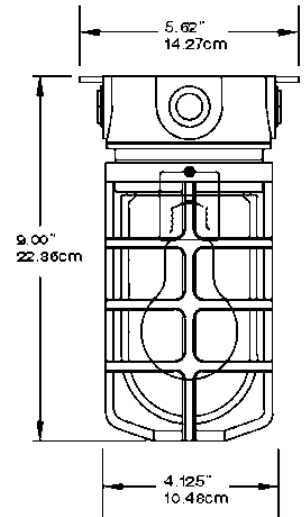

DATOS TÉCNICOS

VOLTAJE	220V / 50Hz
PROTECCIÓN IP/IK	IP65
MATERIAL	ALUMINIO FUNDIDO Y VIDRIO.
OTROS	NO INCLUYE LÁMPARA; BASE E-27.
REFERENCIA	VSK 100CG

CÓDIGO	POTENCIA	DIMENSIONES	APLICACIÓN
545011	100 W	143x229 MM	A TECHO
545013	100 W	180x245 MM	A PARED
545015	100 W	143x229 MM	A TUBO