



HOJA DE DATOS DEL MOTOR

Modelo: **SEMh80-2D**
 Código Rhona: **163428**
 Series: **MONOFÁSICA**

PARÁMETROS ELÉCTRICOS																	
U	CON.	f	P		Serv.	I	n	T	TL/T	TB/T	IL/I	Eficiencia a carga [%]			Factor de potencia a carga [-]		
V	-	Hz	kW	HP	-	A	rpm	N	-	-	-	2/4	3/4	4/4	2/4	3/4	4/4
230	-	50	1.5	2	S1	10.2	2700	5.31	0.7	1.6	2.8	-	-	71	-	-	0.9

DATOS GENERALES			
Clase de eficiencia	-	Nivel de presión de sonido [dB]	-
Tamaño del frame	80	Nivel de potencia de sonido [dB]	-
Número de polos	2	Posición de la caja de terminales	arriba
Método de arranque	DOL	Posibilidad de rotar la caja de terminales	Si
Clase de aislación	F	Rodamiento en lado de accionamiento	62042Z
Alimentador del variador de frecuencia	-	Rodamiento en lado opuesto al accionamiento	62042Z
Arreglo de montaje	IMB3/B5/B35/B14	Reengrase de rodamientos	no
Método de enfriamiento	IC411	Carcasa - material	aluminio
Peso [kg]	13.7	Pie - material	aluminio
Inercia [kgm ²]	0.0021	Escudos de rodamientos - material	aluminio
Dirección de rotación	CW/CCW	Pintura	RAL5010
Grado de protección	IP 54/IP 55	Ejecución climática	U/2

CONDICIONES AMBIENTALES			
Temperatura ambiente [°C]	de -15 a +40	Altitud sobre el nivel del mar [m]	hasta 1000
Humedad relativa [%]	hasta 95		

ACCESORIOS			
Número de terminales o cables	4	Sensor de temperatura en los rodamientos	no
Entradas de cables o prensaestopas	1	Calefactores de devanado	no
Sensor de temperatura en el devanado	no	Accesorios opcionales	a demanda

ESTÁNDARES	
IEC 60034-1	

CERTIFICADOS	
a demanda	

INFORMACIÓN ADICIONAL			
Capacitor de marcha [µF/V]	40	Capacitor de arranque [µF/V]	-

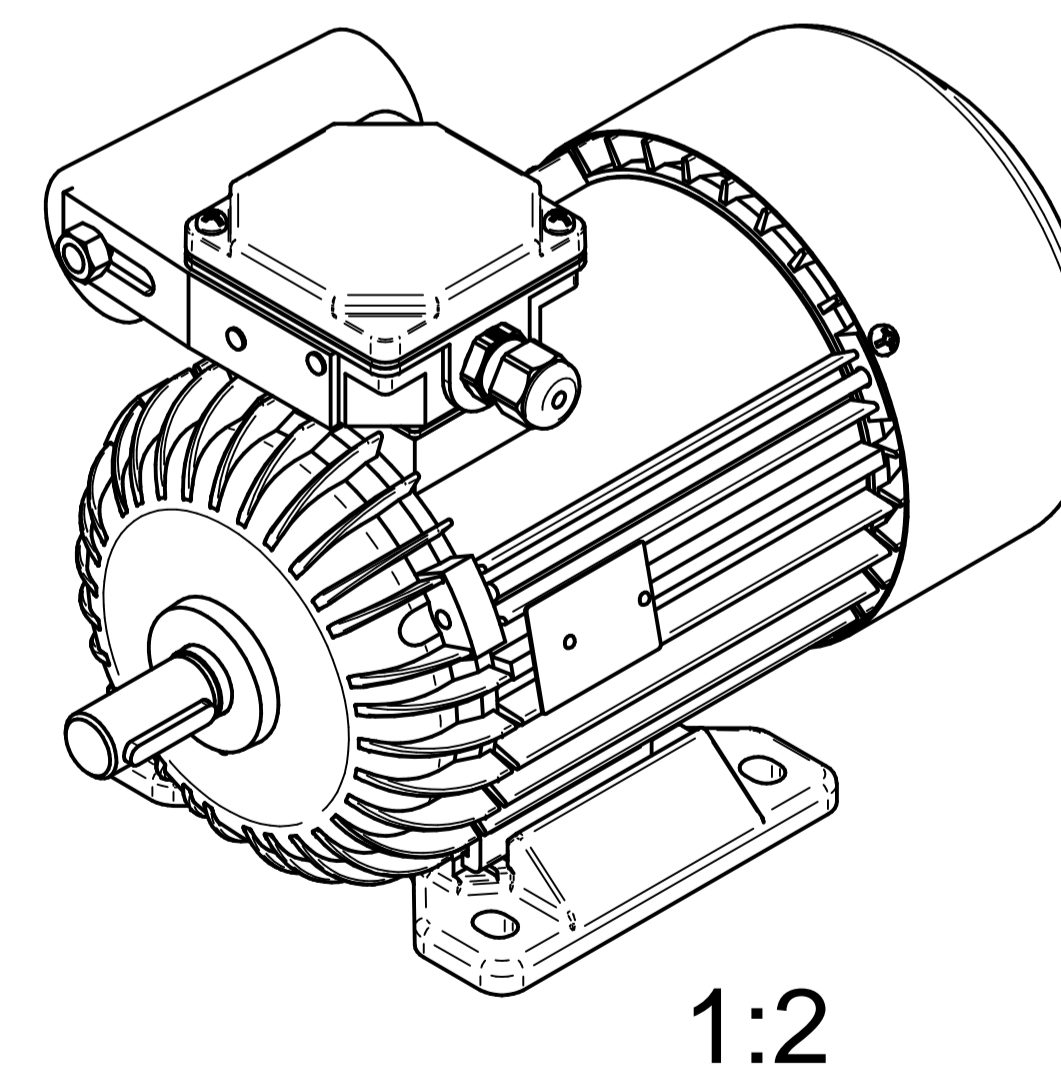
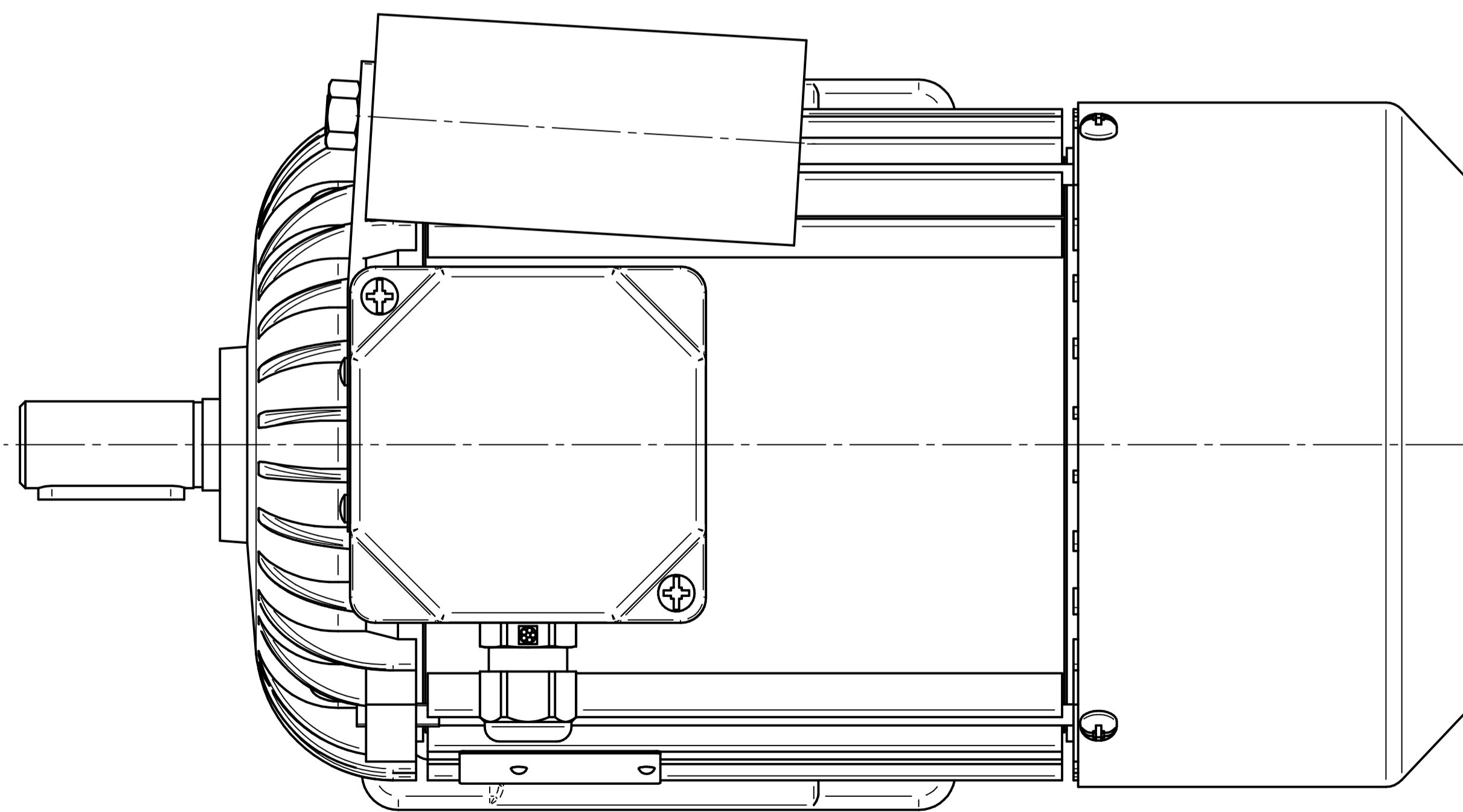
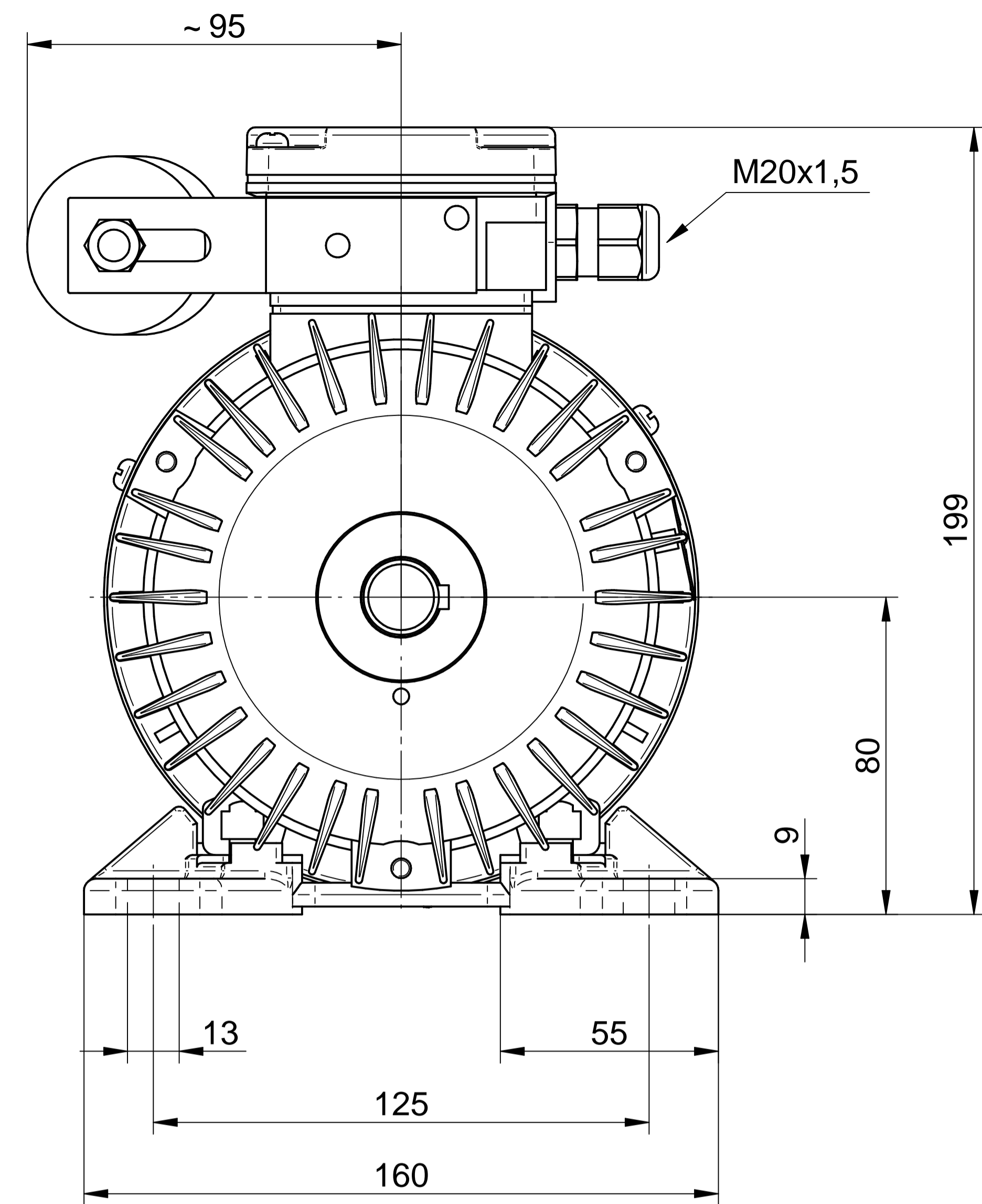
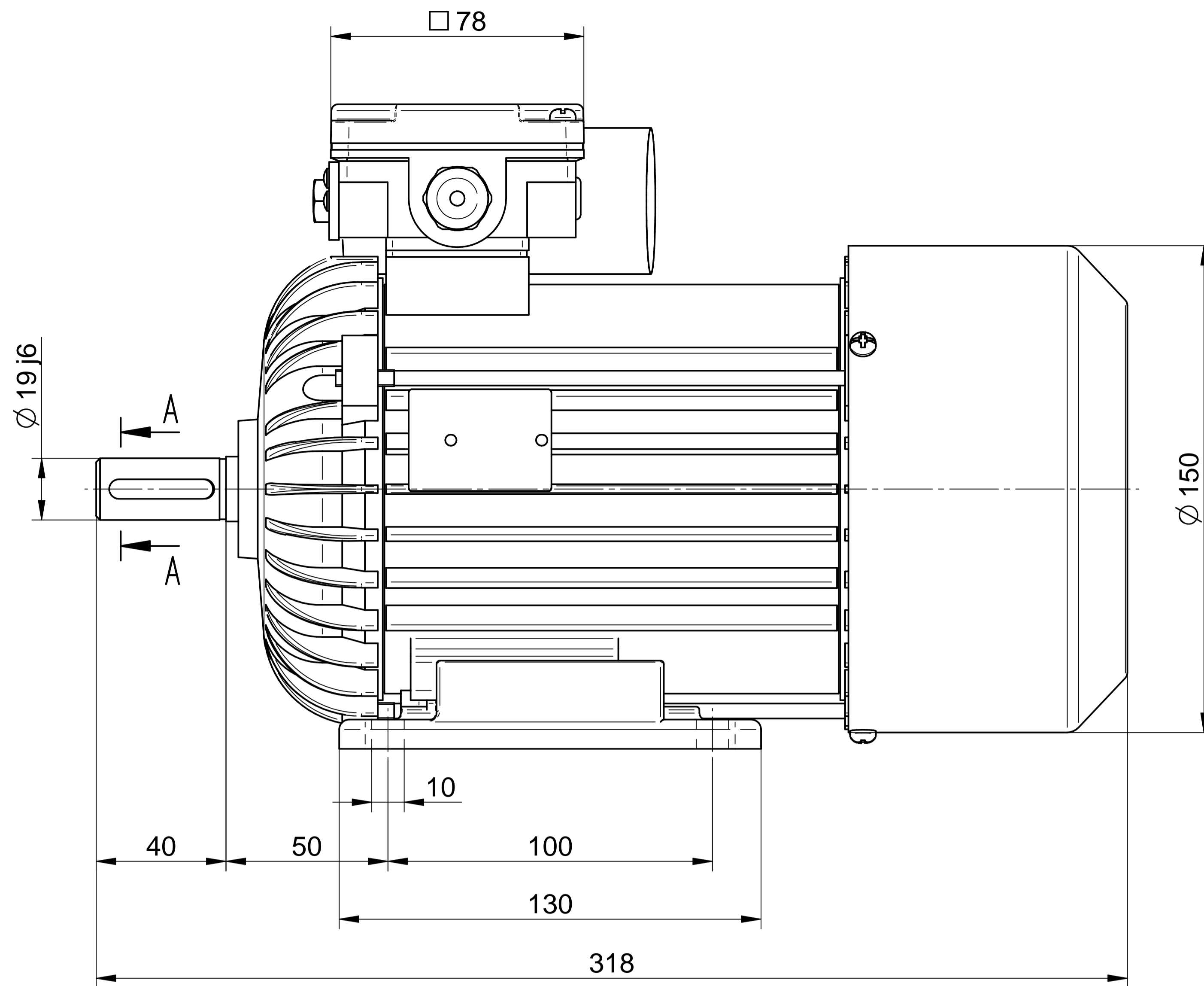
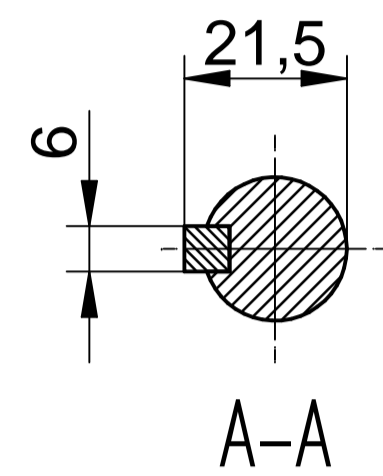

Cantoni[®]
GROUP



BESEL S.A.
FABRYKA SILNIKÓW ELEKTRYCZNYCH

Motor type

SE(M)h80-2D

Scale

1:1

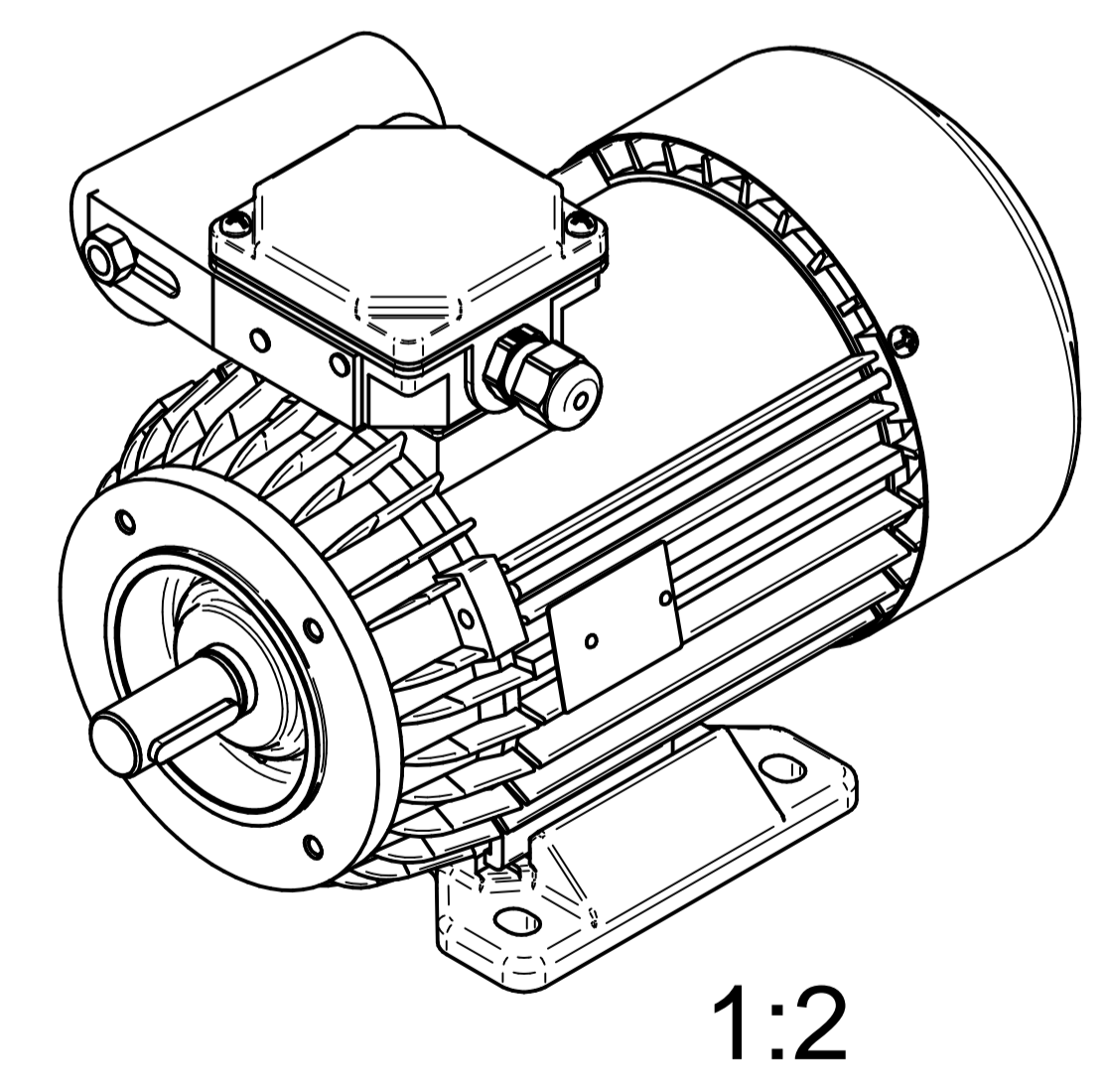
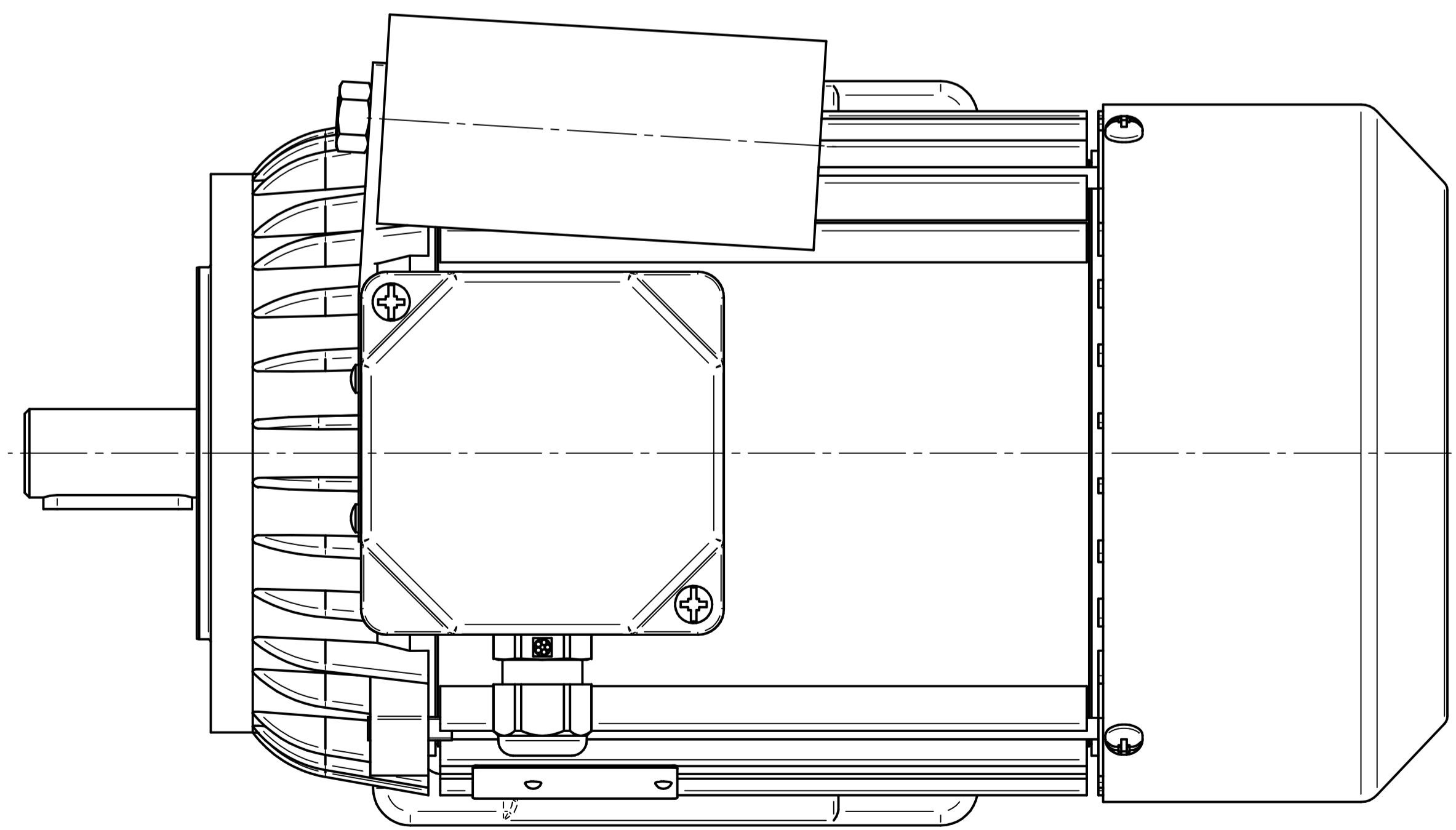
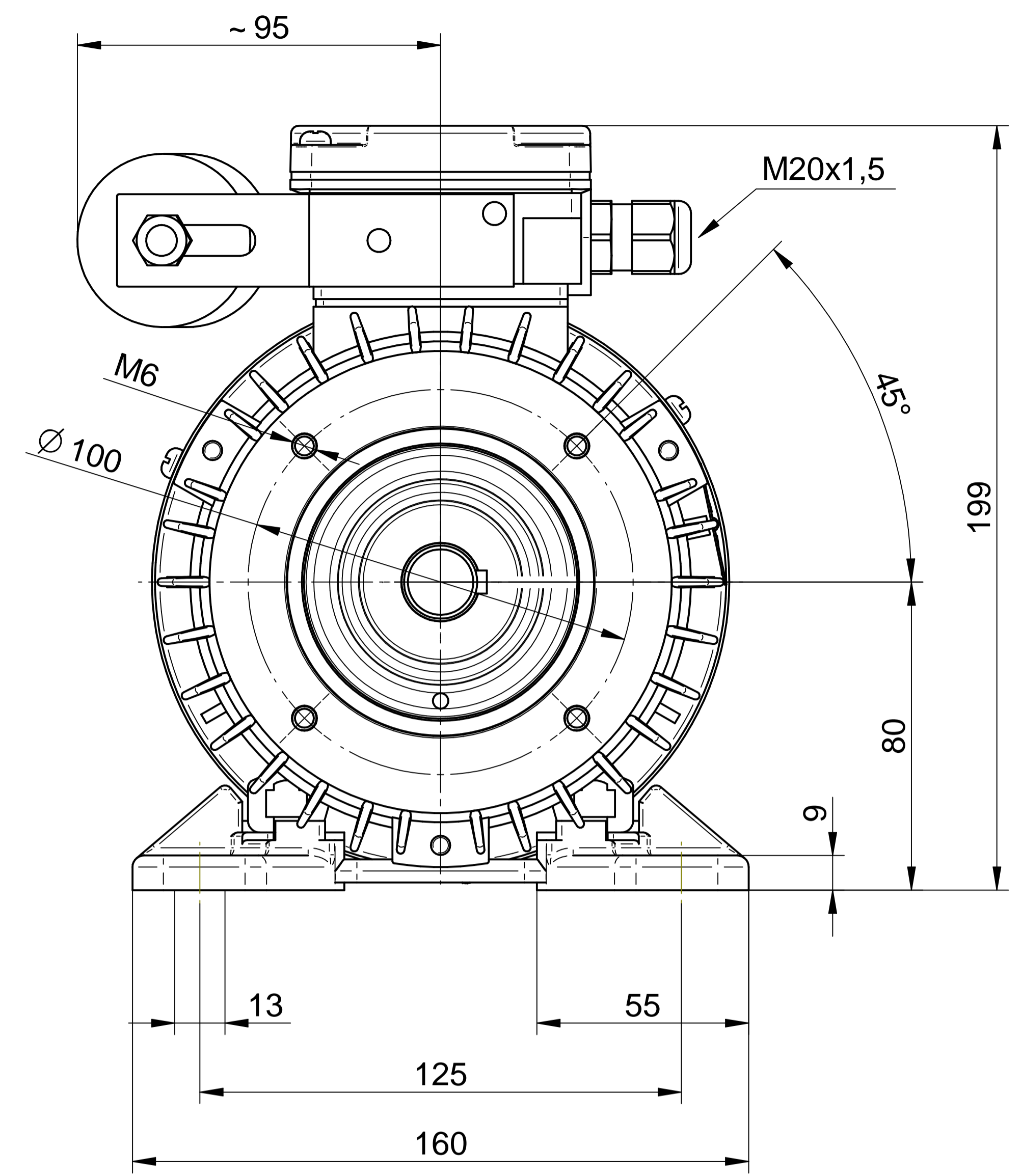
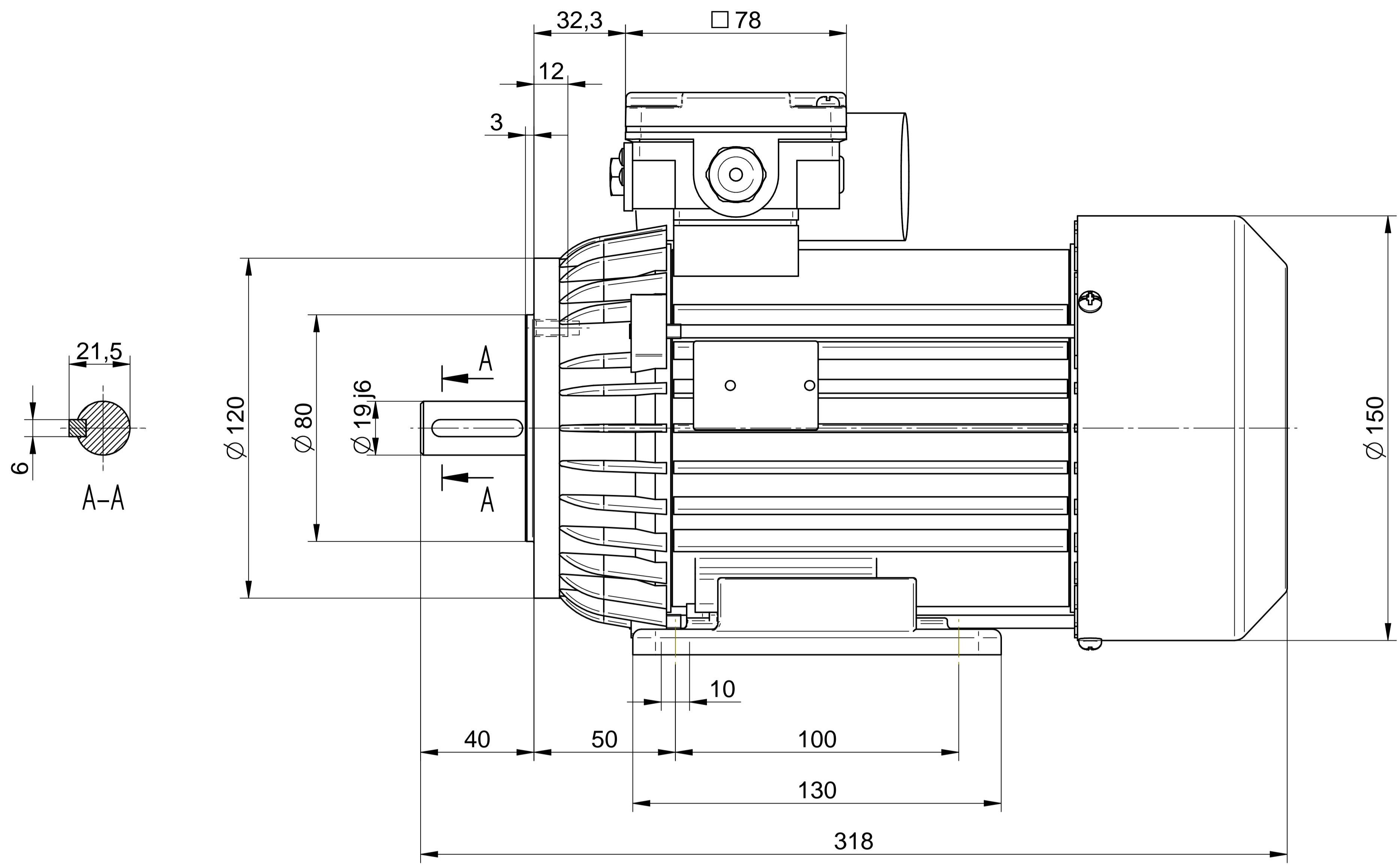

Cantoni®
GROUP



BESEL S.A.
FABRYKA SILNIKÓW ELEKTRYCZNYCH

Motor type

SE(M)Lh80-2D2

Scale

1:1

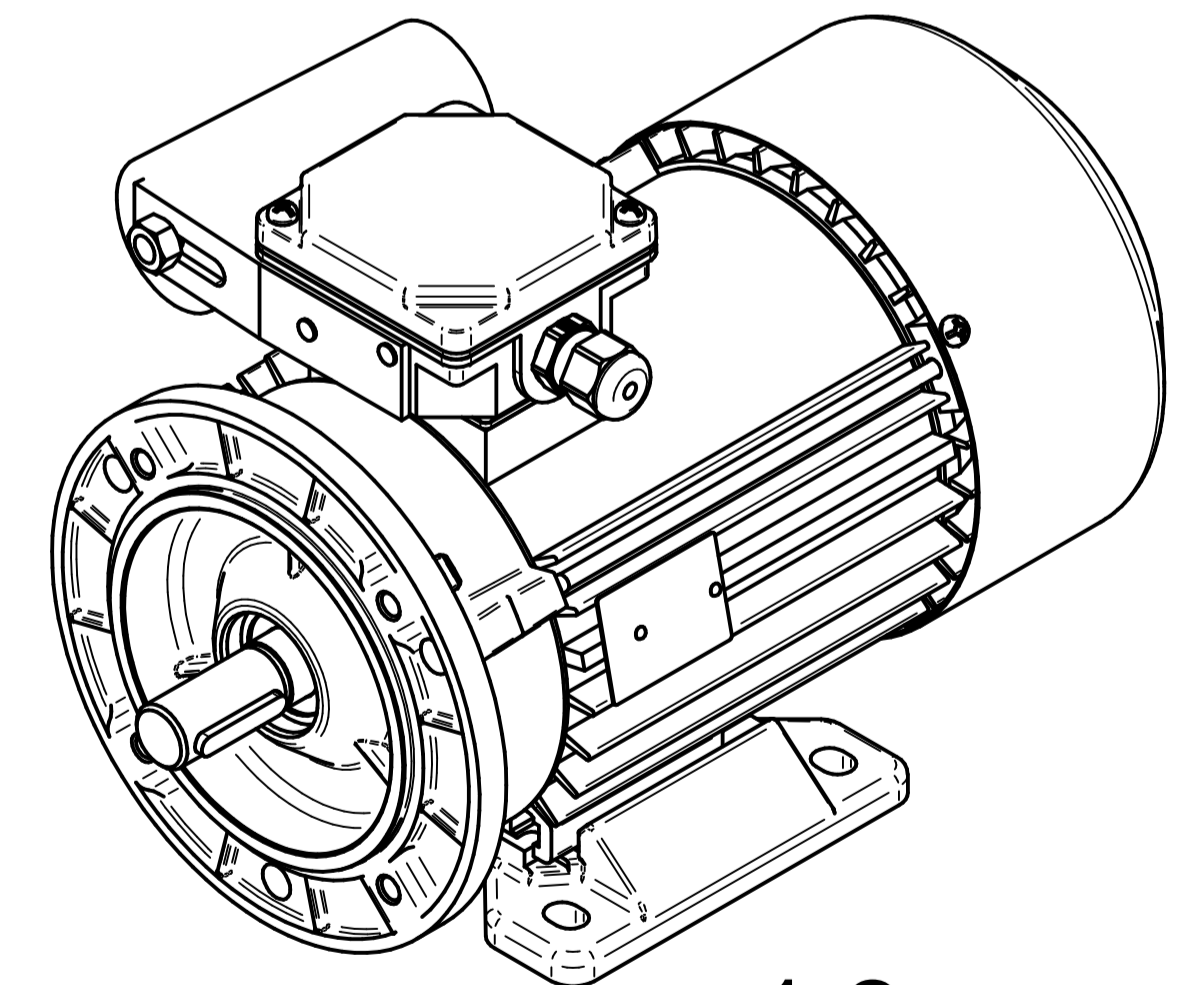
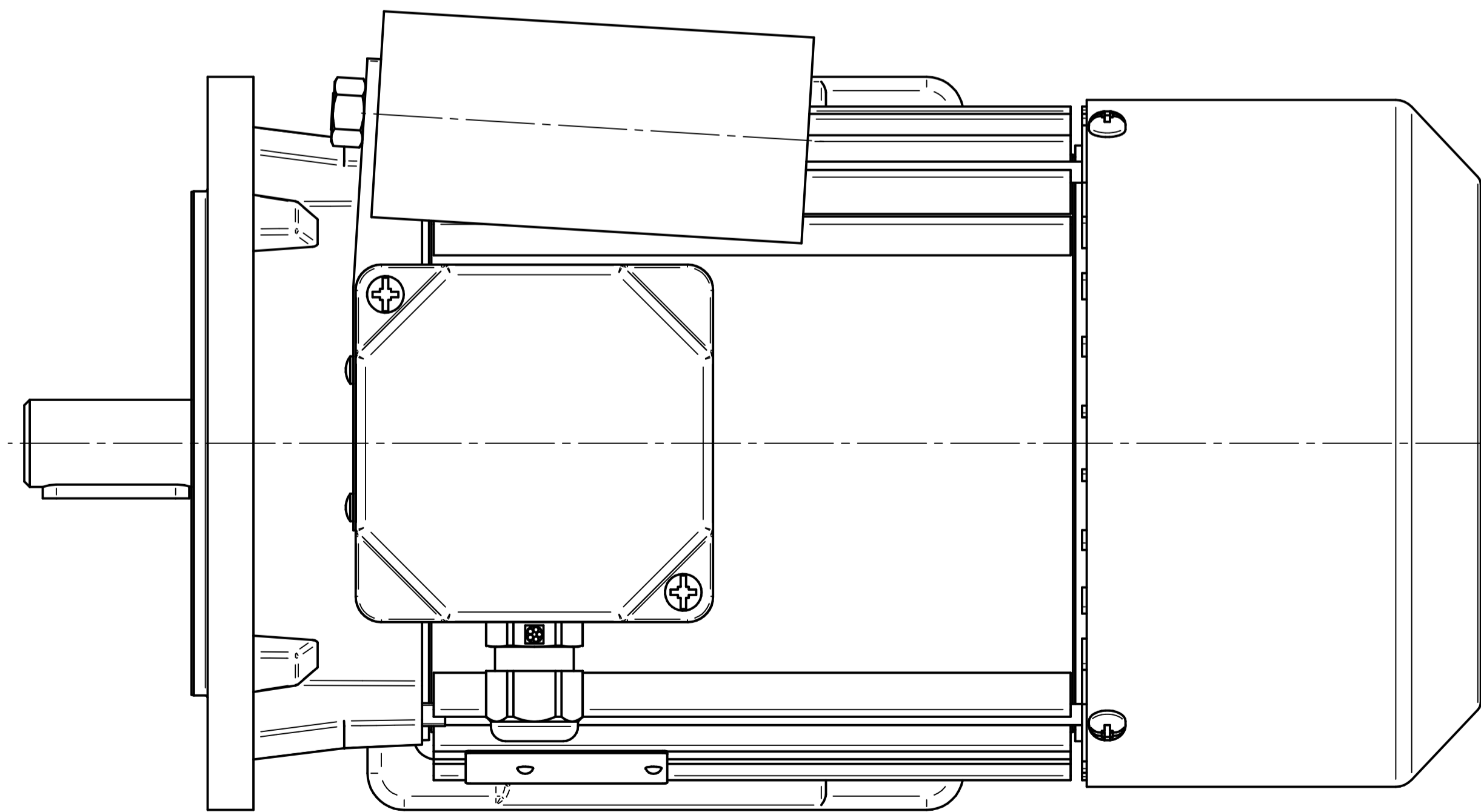
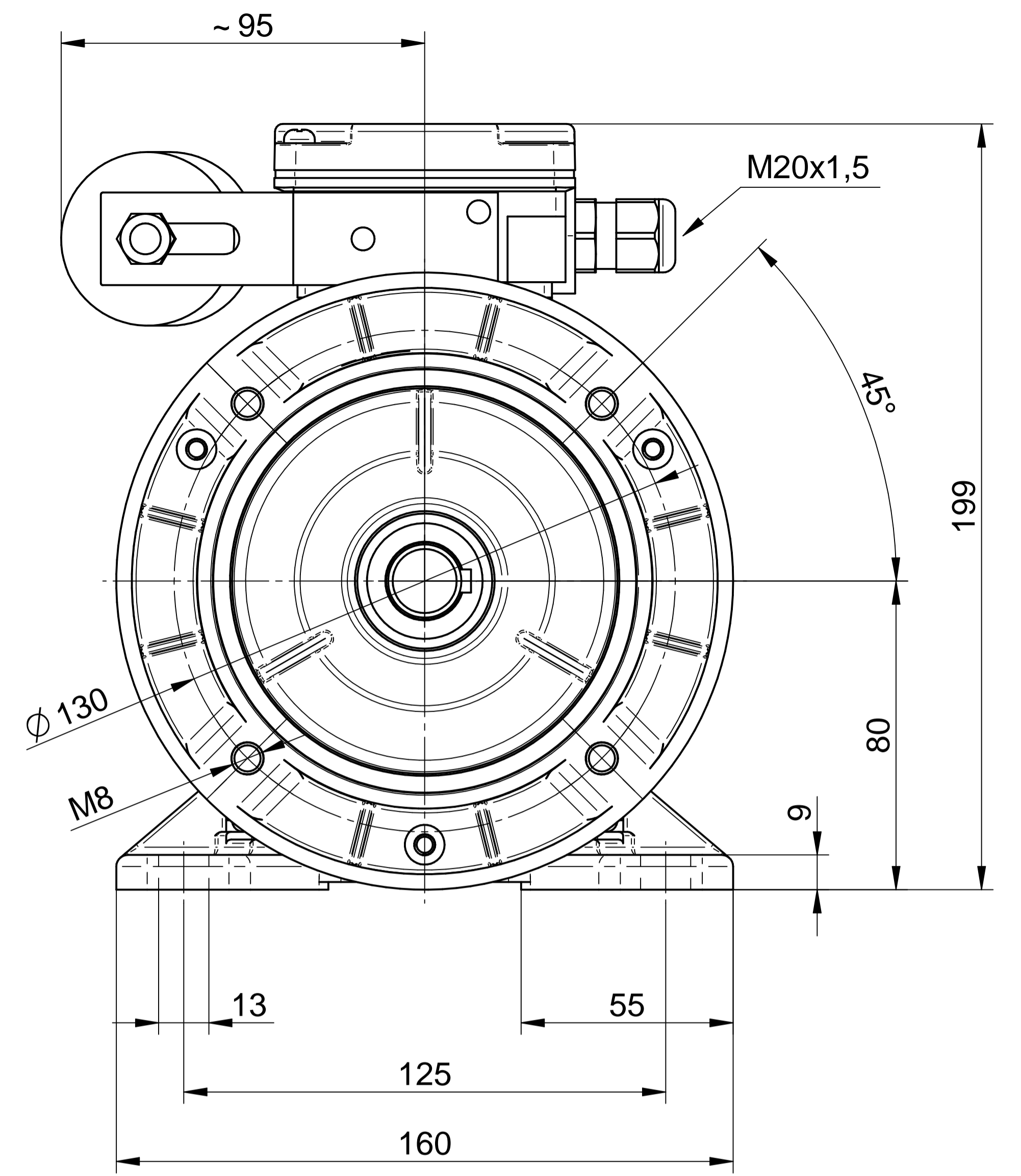
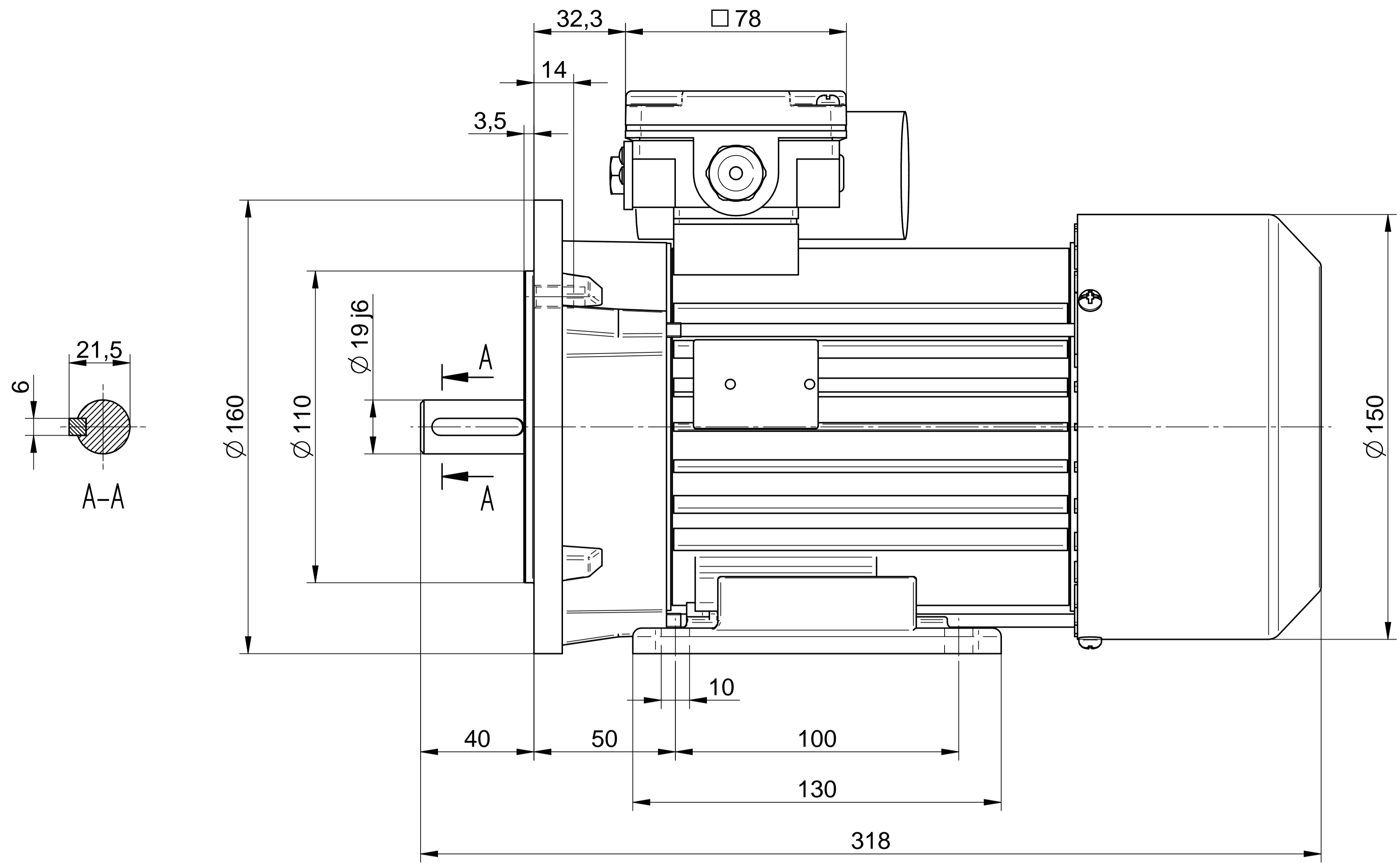

1:2

Cantoni®
GROUP



BESEL S.A.
FABRYKA SILNIKÓW ELEKTRYCZNYCH

Motor type

SE(M)Lh80-2D1

Scale

1:1

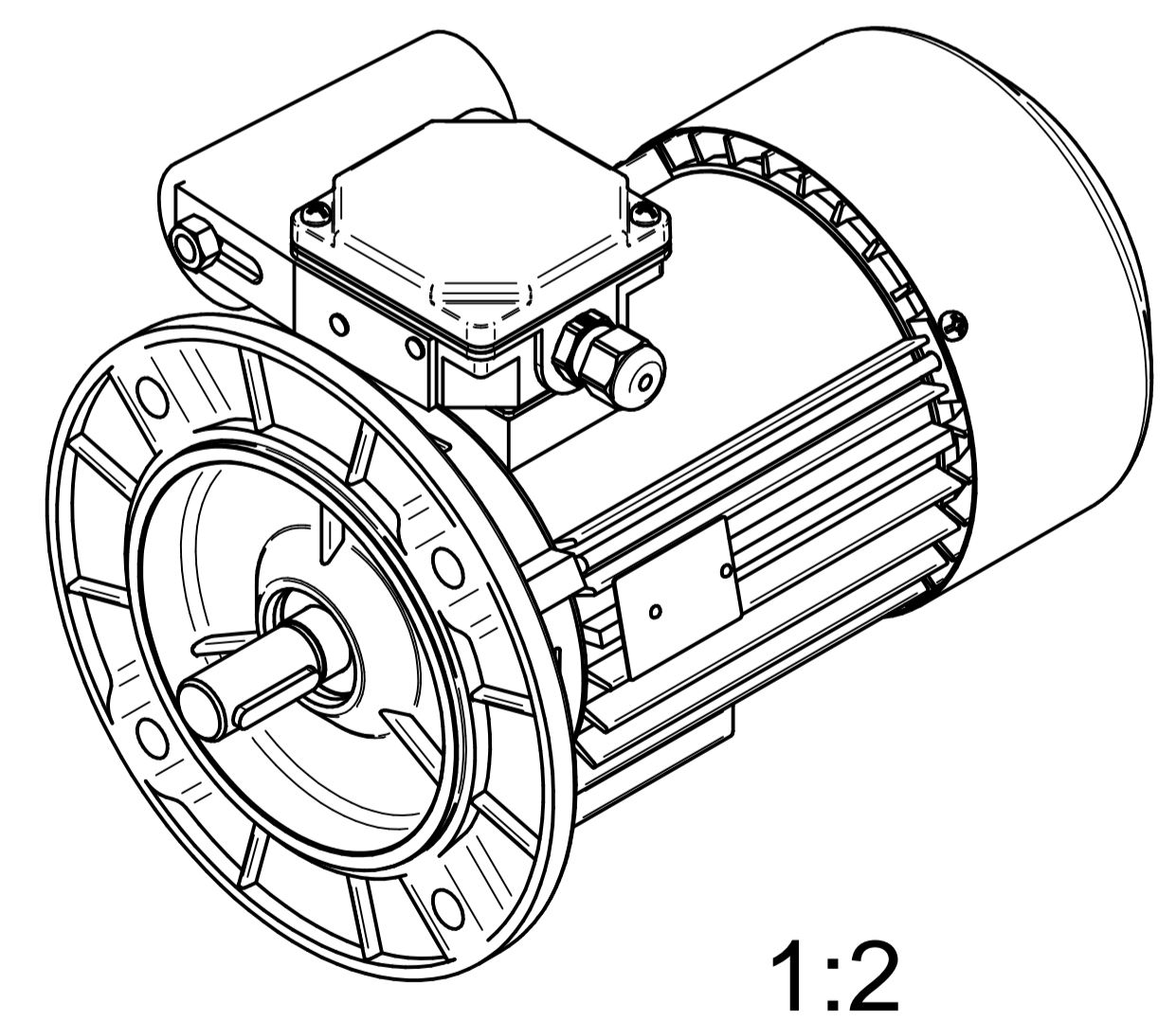
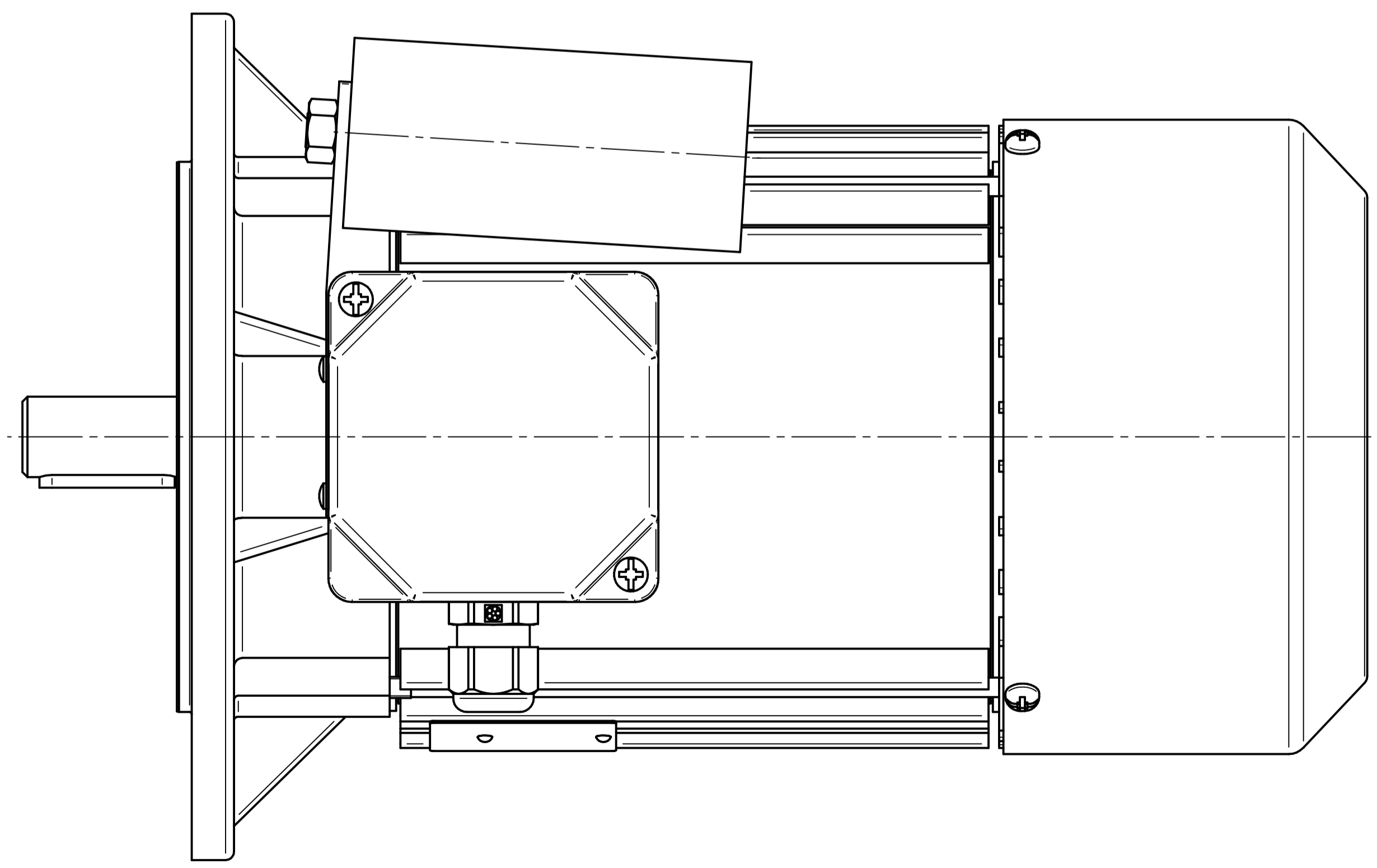
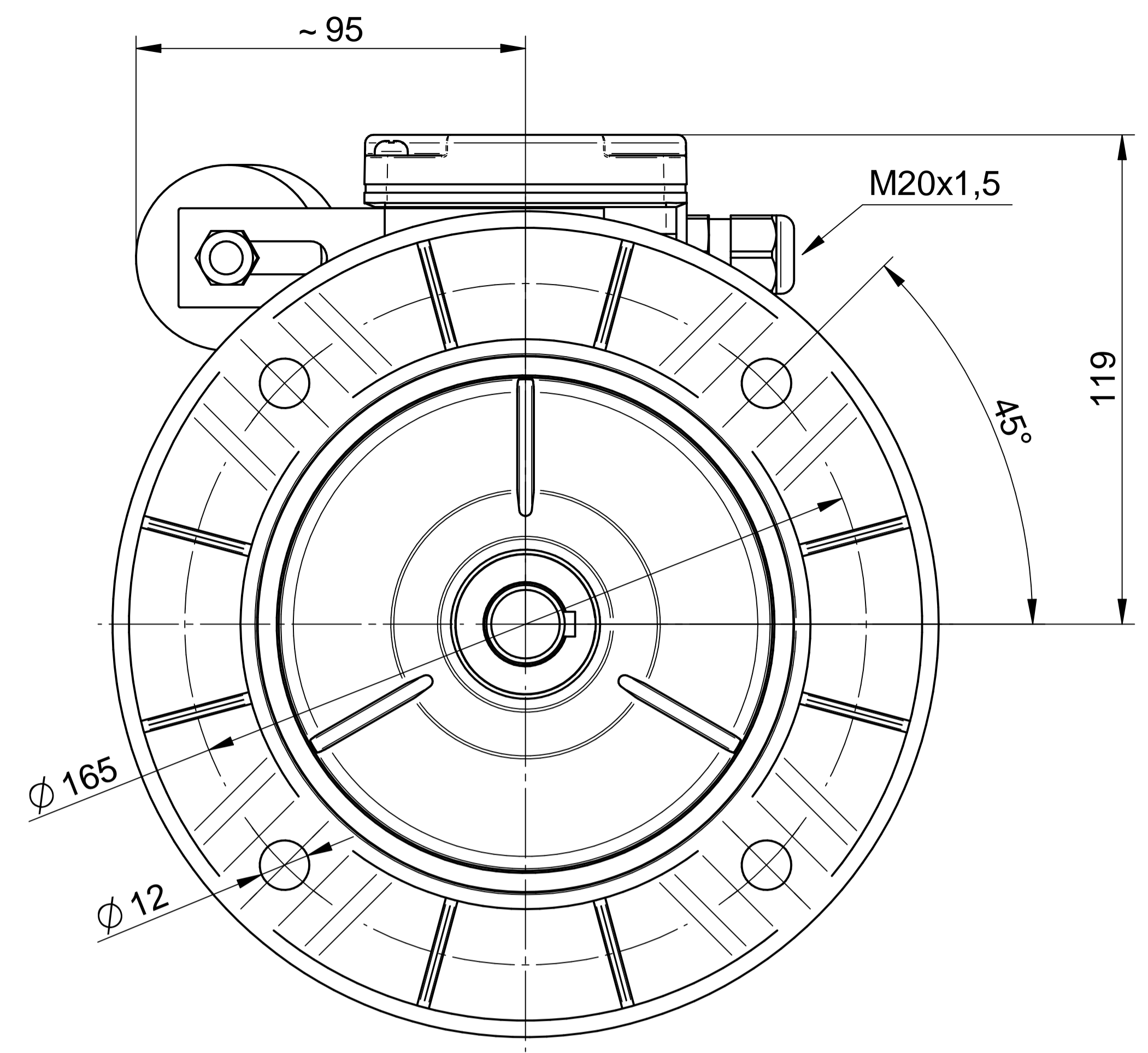
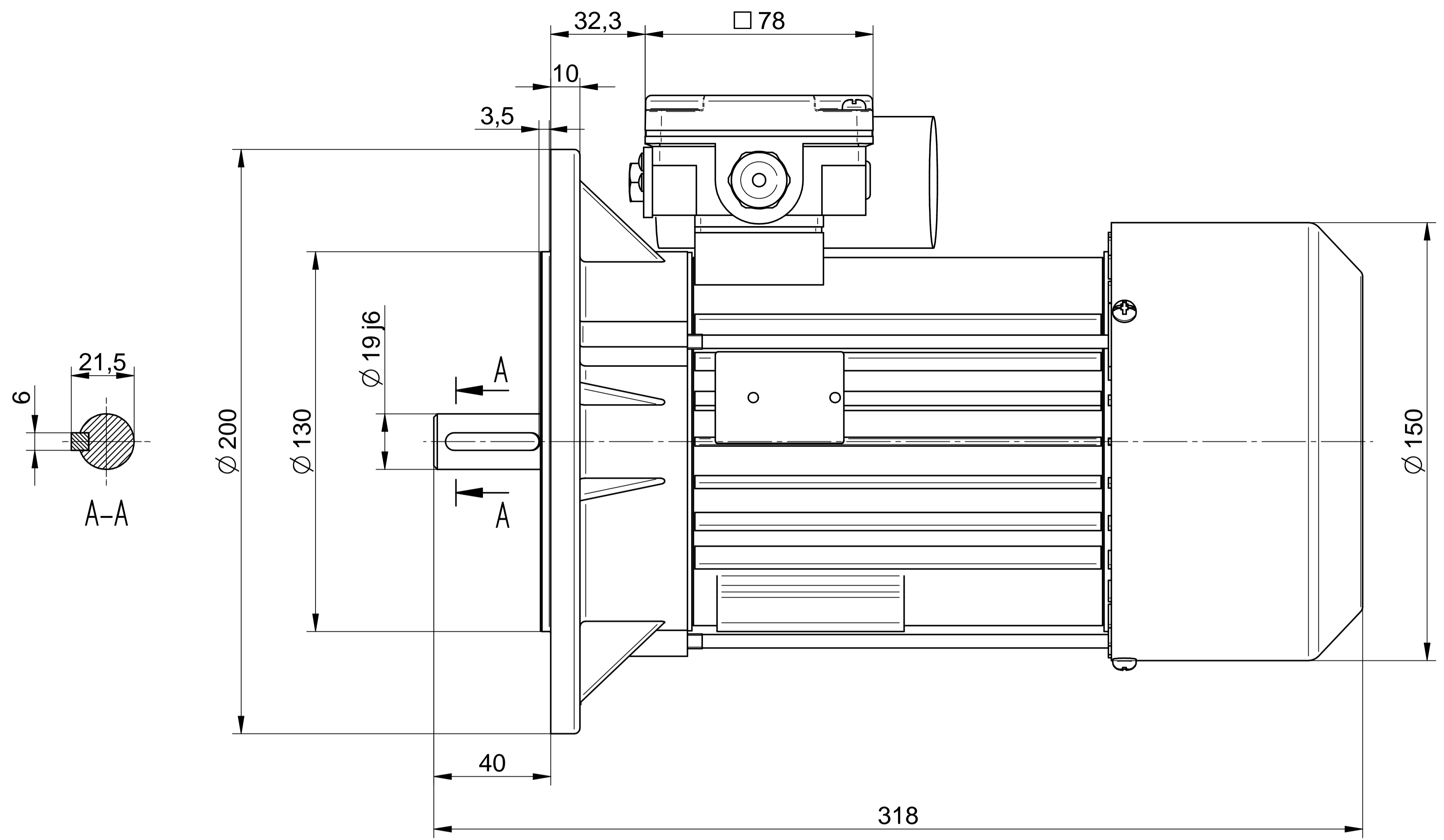

1:2

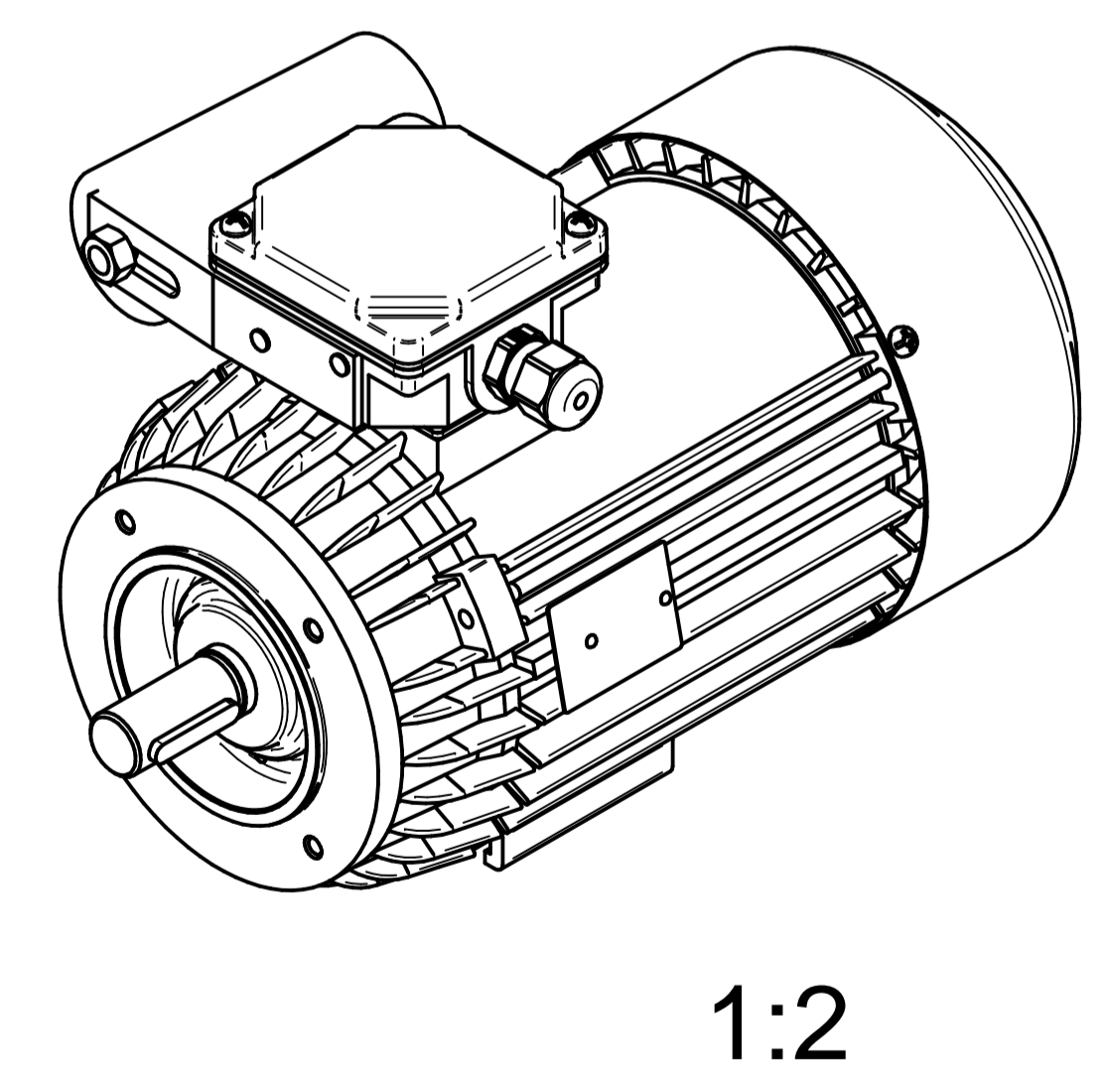
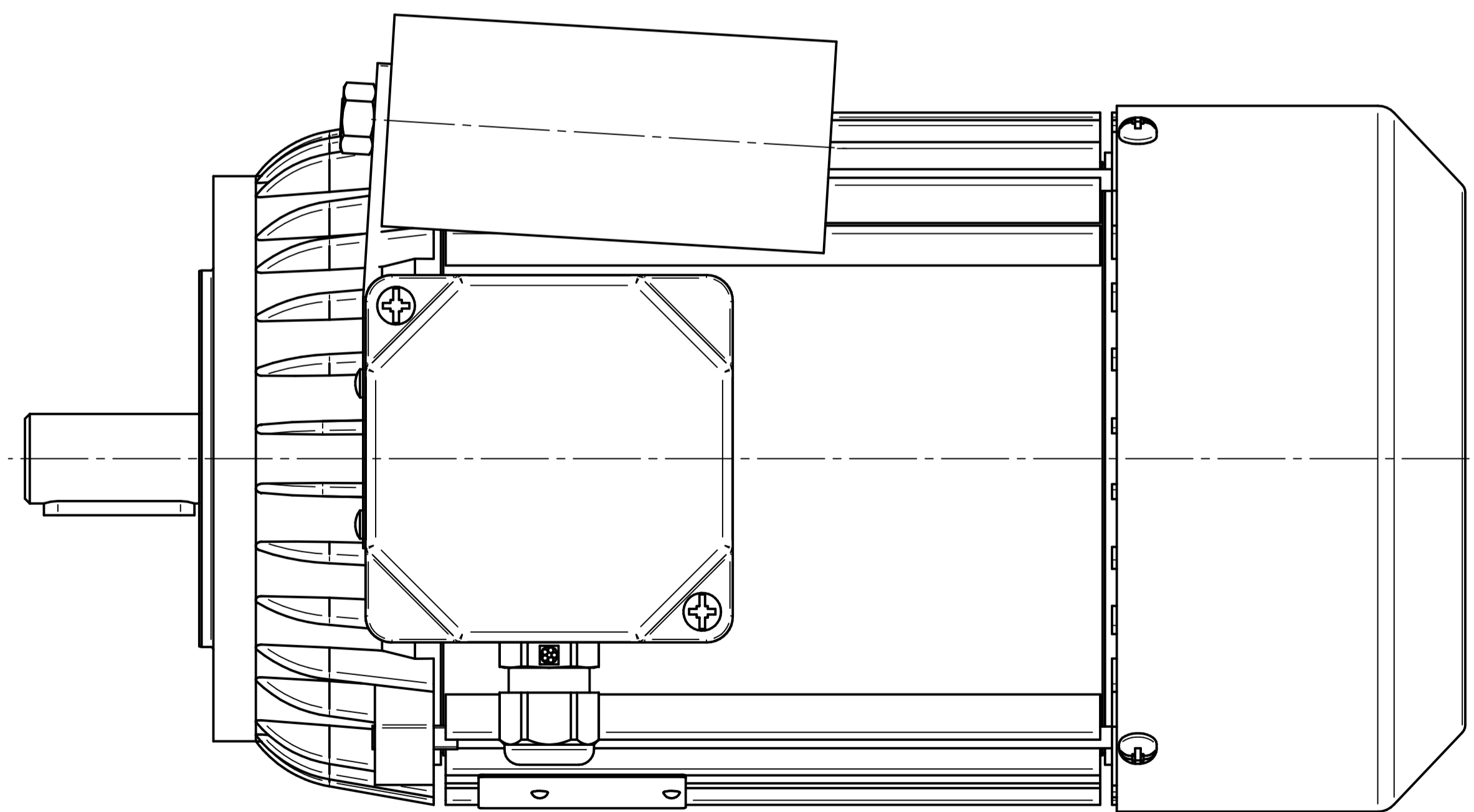
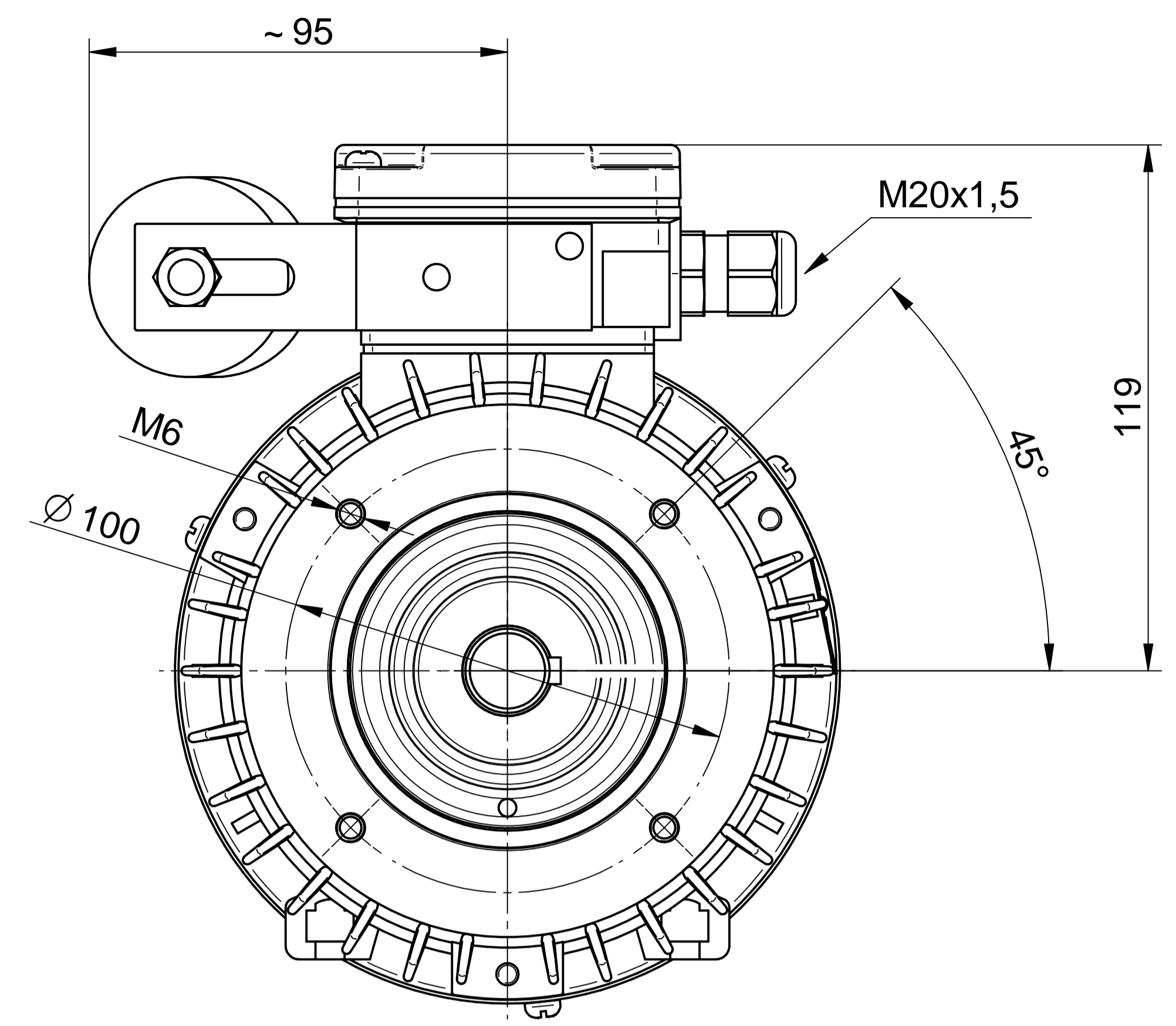
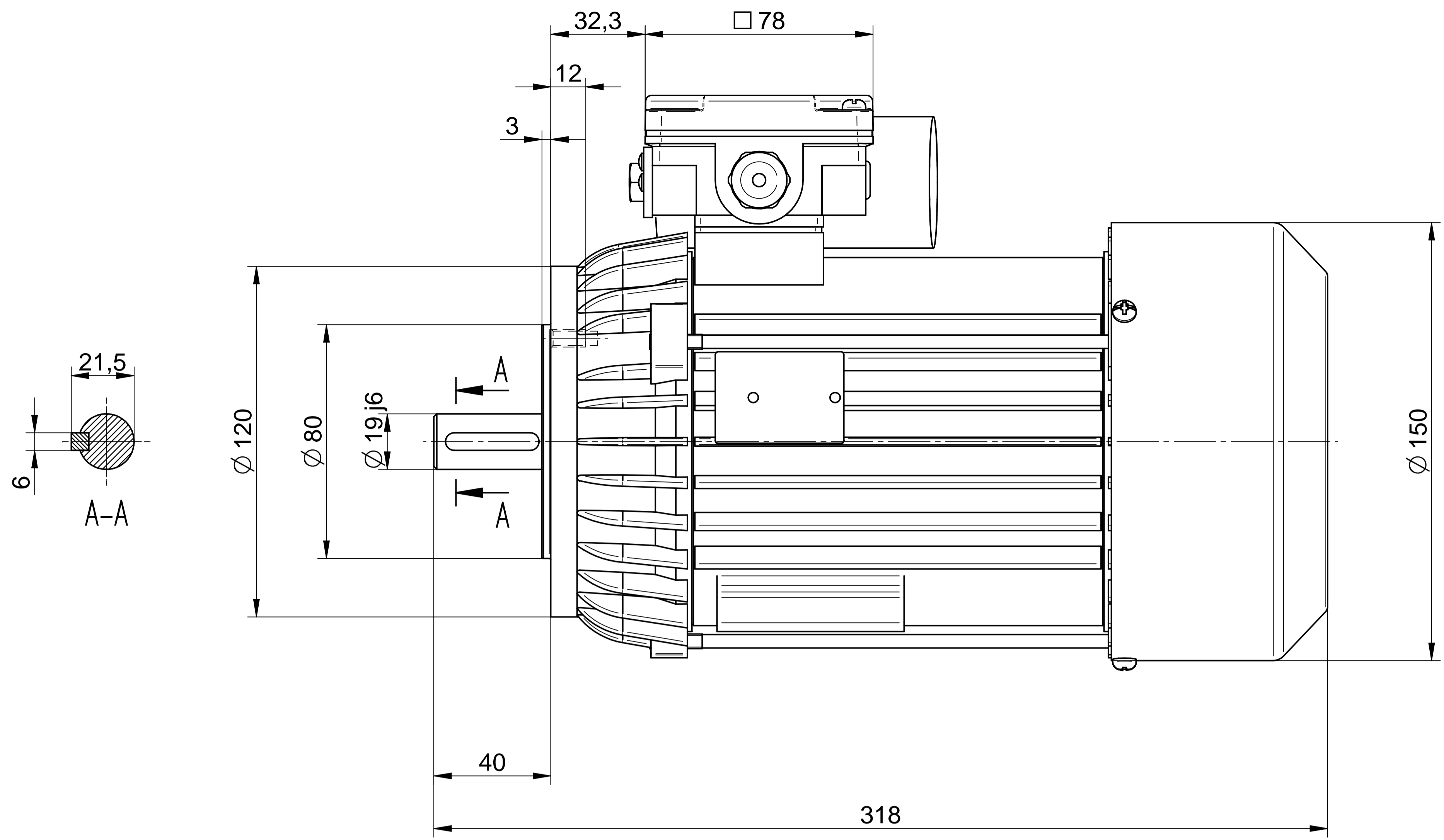

Cantoni®
GROUP



BESEL S.A.
FABRYKA SILNIKÓW ELEKTRYCZNYCH

Motor type

SE(M)Kh80-2D2

Scale

1:1

