

- Ultra-slim, high sensitivity and low consumption, the maximum load power 6A.
- Reasonable structure, meets environmental protection requirements, the control voltage range can be extended with matching sockets.
- Shenler industrial relays are widely used in the output signal and safety drive of PLC, CNC system, robot, intelligent manufacturing and other control systems. It is the best choice to realize remote control, production and processing, packaging, transportation, testing, storage and other equipment and automatic assembly lines.

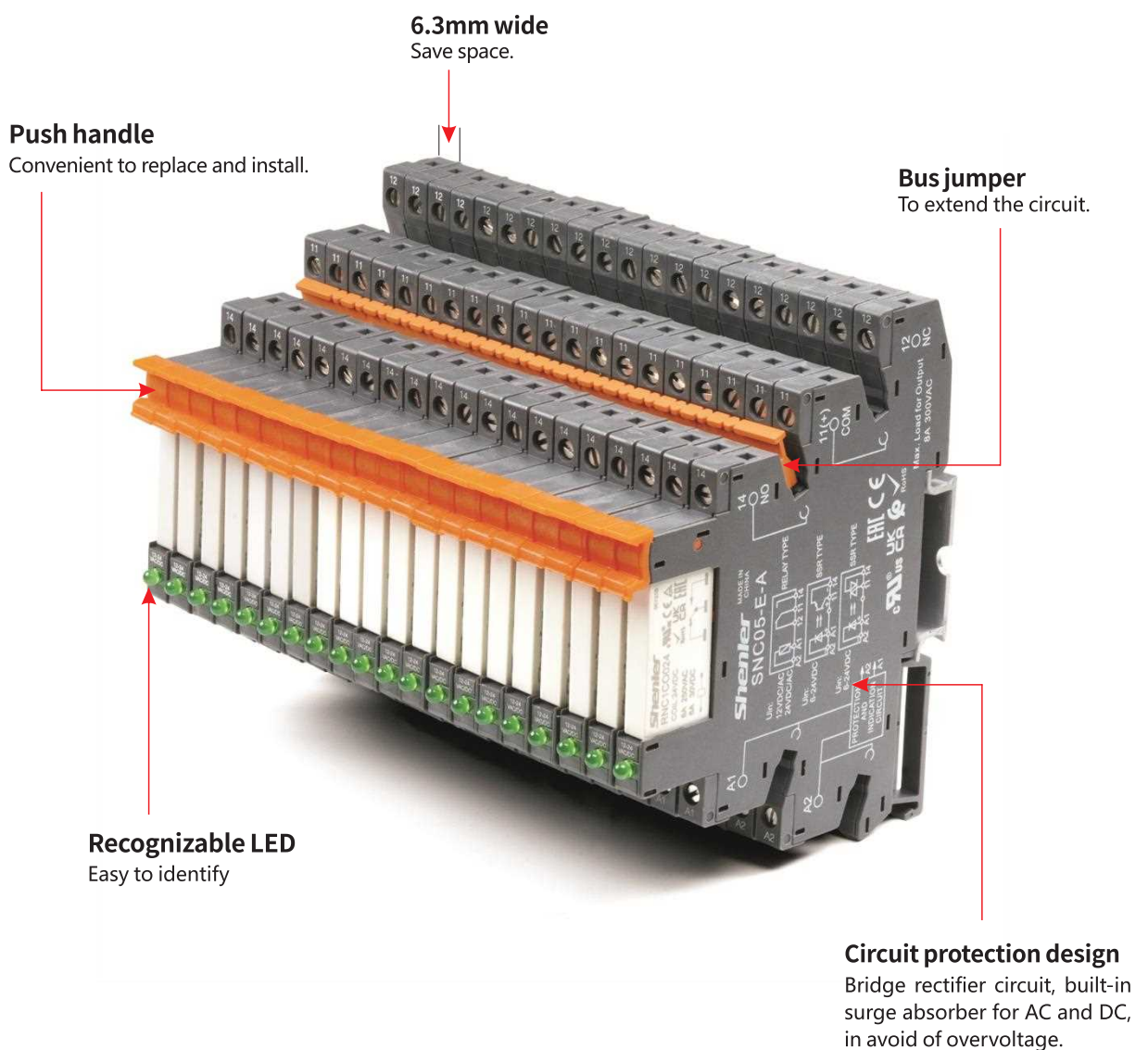



Relay

+



Socket

=



Relay module

RNC □ □ □ □

Other options

Blank: Conventional
A: Gold plated contact

Coil voltage code

Code	005	006	012	024
Voltage (V DC)	5	6	12	24
Code	048	060		
Voltage (V DC)	48	60		

Terminal arrangement

O: Vertical pin
P: Horizontal pin

Contact form

1A: (NO)
1C: (CO)

Series name

Characteristics

Configuration	1A,1C
Load Resistance	6A/250VAC 30VDC
Max. switching capacity (resistive)	1500VA, 180W
Min. switching capacity	170mW(17V/10mA)
Initial contact resistance	≤100mΩ (gold plated contact ≤ 30mΩ)
Material	Ag alloy
Electrical durability (normal temperature)(frequency 1s on, 5s off)	NO: 6x10 ⁴ Cycles (600 Ops/h); NC: 3x10 ⁴ Cycles (600 Ops/h)
Mechanical durability	≥2x10 ⁷ Cycles (18000 Ops/h)
Pick-up voltage (23°C) (Rated voltage)	DC:≤75%
Drop-out voltage (23°C) (Rated voltage)	DC:≥5%
Maximum voltage (23°C) (Rated voltage)	110%
Insulation resistance	≥500MΩ (500VDC)
Coil operating power	3~24 VDC(W) approx. 0.17W 48~60 VDC(W) approx. 0.21W
Operate time (at nominal voltage)	≤8ms
Release time (at nominal voltage)	≤4ms
Initial breakdown voltage	Between open contacts 1000VAC/1min (leakage current 1mA) Between contacts and coil 4000VAC/1min (leakage current 1mA)
Insulation characteristics	Rated voltage 250VAC Pollution level 3
IEC 60664 UL840	Overvoltage level III
Impulse withstand voltage (waveform: 1.2/50μs)	4000V
Protection level	IP20
Storage temperature/ humidity	-55~+85°C/ ≤85%RH (18 months)
Working temperature/ humidity	-40~+85°C/ 5%~85%RH (No condensation)
Air pressure	86~106KPa
Shock resistance	10G (half-sine shock pulse: 11ms)
Vibration resistance	10~55Hz double-amplitude:1.0mm
Mounting	PCB
Unit weight	approx. 6g

Coil Specifications (23°C)

Nominal voltage V.DC (0.17W)	5	6	12	24
Coil resistance Ω	147	212	847	3250
Nominal voltage V.DC (0.21W)	48	60		
Coil resistance Ω	10971	17143		

Coil resistance: under coil voltage 110V are measured with tolerance of ±10%Ω.

Contact Specification

RNC1A, 1C

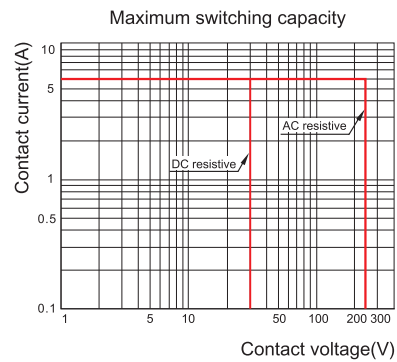
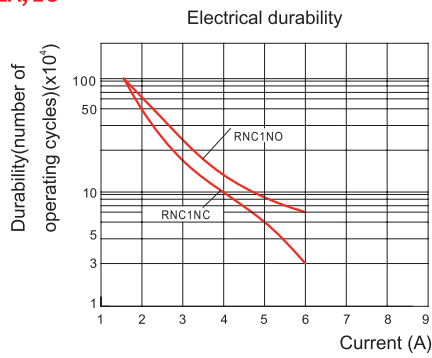

Dimensions (mm)

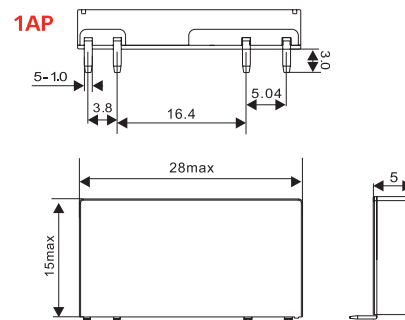
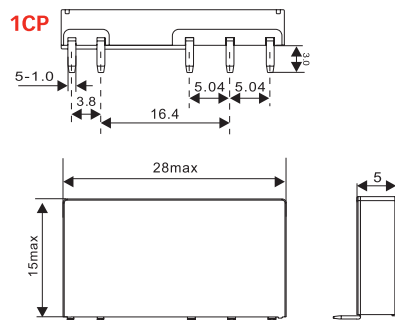
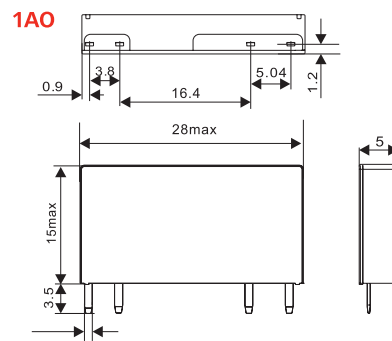
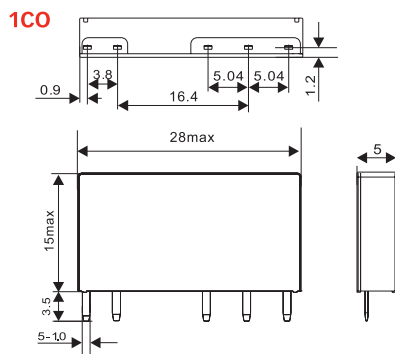

Wiring Diagrams

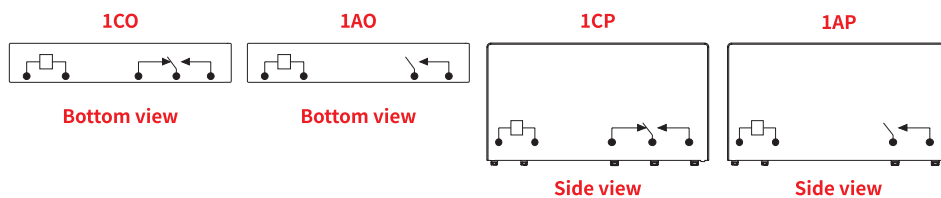

Characteristics

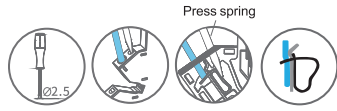

SNC05-S

Model No.	Input	Relay
SNC05-S-A	12~24V	12~24VDC
SNC05-S-B	48~60V	48~60VDC
SNC05-S-C	110V	60VDC
SNC05-S-D	230V	60VDC

Characteristics			
Nominal load	Current	A	8
	Voltage	V	300
Dielectric strength	Between coil and contact	V/min	4000
	Between contacts	V/min	2000
Wire size	AWG/mm ² 20-16/0.5-1.5		
Ambient temperature	°C -40~+85		
Unit weight	g 25		

Accessories		
Bus jumper	ID tag	Partition plate
		
SN20B	SN64P	SN20S

*SNC05-S-DR optional, anti-interference function.

Dimensions (mm)

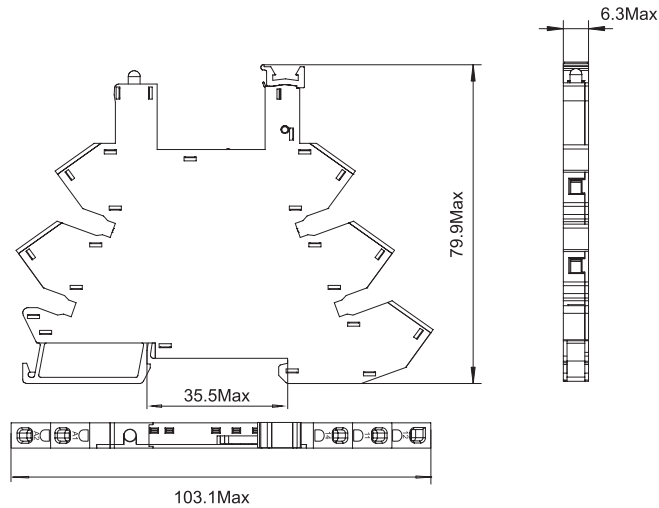

Connection Diagrams

