

Slim Remote I/O

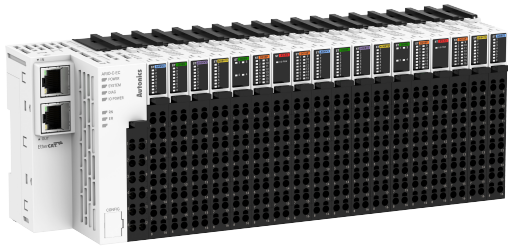

ARIO Series PRODUCT MANUAL

For your safety, read and follow the considerations written in the instruction manual, other manuals and Autonics website.

The specifications, dimensions, etc. are subject to change without notice for product improvement. Some models may be discontinued without notice.

Features

- Industrial Ethernet/Fieldbus serial communication I/O for Smart Factory
- Multiple I/O distribution control using PLCs and industrial PCs.
- Coupler: available in 8 different communication protocols
 - EtherCAT, CC-Link V1/V2, ProfiNet, ProfiBus, EtherNet/IP, DeviceNet, Modbus TCP compatible, Modbus RTU compatible
- Module: various input/output modules, power module
 - Bus power + Field power, Bus power/Field power, digital input/output (4/8/16 channels), analog input/output (2/4/8 channels), temperature input (4/8 channels)
 - Expandable up to 64 modules (may vary by communication type)
- Hot-swap feature
 - : Terminal and body units can be removed/swapped during operation for easy maintenance
- Push-in connection method: easy wire connection without requiring additional tools
- Easy module attachment and removal on DIN rails
- Comprehensive device management software DAQMaster for improved convenience
- Module settings, real-time control/monitoring/diagnosis of input/output signals
- Virtual mode allows simulation of product set up and offers set up recommendations

Safety Considerations

- Observe all 'Safety Considerations' for safe and proper operation to avoid hazards.
- ⚠ symbol indicates caution due to special circumstances in which hazards may occur.

⚠ Warning Failure to follow instructions may result in serious injury or death.

- 01. Fail-safe device must be installed when using the unit with machinery that may cause serious injury or substantial economic loss. (e.g., nuclear power control, medical equipment, ships, vehicles, railways, aircraft, combustion apparatus, safety equipment, crime/disaster prevention devices, etc.)**
Failure to follow this instruction may result in personal injury, fire or economic loss.
- 02. Do not use the unit in the place where flammable/explosive/corrosive gas, high humidity, direct sunlight, radiant heat, vibration, impact, or salinity may be present.**
Failure to follow this instruction may result in explosion or fire.
- 03. Do not disassemble or modify the unit.**
Failure to follow this instruction may result in fire.
- 04. Do not connect, repair, or inspect the unit while connected to a power source.**
Failure to follow this instruction may result in fire.
- 05. Check 'Connections' before wiring.**
Failure to follow this instruction may result in fire.

⚠ Caution Failure to follow instructions may result in injury or product damage.

- 01. Use the unit within the rated specifications.**
Failure to follow this instruction may result in fire or shortening the life cycle of the product.
- 02. Use dry cloth to clean the unit, and do not use water or organic solvent.**
Failure to follow this instruction may result in fire or electric shock.
- 03. When connecting the power input and output, use AWG 22-16 cable and check the connecting method of crimp terminal.**
Failure to follow this instruction may result in fire or malfunction due to contact failure.
- 04. Keep the product away from metal chip, dust, and wire residue which flow into the unit.**
Failure to follow this instruction may result in fire or product damage.
- 05. Do not connect or disconnect connector (terminal) wire or power, when the product is operating.**
Failure to follow this instruction may result in fire or malfunction of the product.

Cautions during Use

- Follow instructions in 'Cautions during Use'.
Otherwise, It may cause unexpected accidents.
- BUS power and I/O power should be insulated by the individually insulated power device.
- Power supply should be insulated and limited voltage/current or Class 2, SELV power supply device.
- Keep away from high voltage lines or power lines to prevent inductive noise.
In case of installing power line and input signal line closely, use line filter or varistor at power line and shielded wire at input signal line. For stable operation, use shield wire and ferrite core, when wiring communication wire, power wire, or signal wire.
- Do not use near the equipment which generates strong magnetic force or high frequency noise.
- Use the rated standard cables and connectors. Do not apply excessive power when connecting or disconnecting the connectors of the product.
- Do not touch the module communication connector part of the base.
- Do not connect, or remove the base while connected to a power source.
For removing the terminal, body or base, do not operate units for a long time without it.
- This unit may be used in the following environments.
 - Indoors (in the environment condition rated in 'Specifications')
 - Altitude max. 2,000 m
 - Pollution degree 2
 - Installation category II

Definitions of Terms

This section introduces specific terms and definitions commonly used in the ARIO series manuals, and is designed to provide clear understanding and guidance for you to properly use the products.

Field Network

A collective term for field buses and industrial Ethernet, enabling distributed control of inputs/outputs in factory and process automation.⁰¹⁾

FieldBus

A network designed for factory automation based on serial communication, which includes CC-Link, PROFIBUS, DeviceNet, and Modbus/RTU.⁰²⁾

Industrial Ethernet

A network designed for factory automation based on the Ethernet, which includes EtherCAT, PROFINET, EtherNet/IP, and Modbus/TCP.

Autonics BUS (ABUS)

A communication protocol designed for data exchange between couplers and modules in the ARIO series.

Coupler

This product acts as a slave unit, exchanging data with the master in a field network and managing the input/output signals for modules.

Module

This product manages the input/output signals for external device, exchanging data with the coupler.

Unit

A combination of coupler and modules to perform specific functions.

Terminal

A component of the ARIO series designed for connecting input/output signals and power, ensuring proper wiring for operation.

Body

A component of the ARIO series designed for the function control and management in modules.

Base

A component of the ARIO series designed for conveying power and communication line for ABUS, as well as facilitating the transmission of field power and input/output signals.

Hole

Circular openings in the terminal for wiring connections.

Groove

Semi-circular spaces above holes for easier wire removal.

Channel

The number of digital or analog input/output signals. (e.g., the signals in input/output modules are represented as 4/8/16 channels).

Node

A unit by which a master in a field network system recognizes a slave coupler. (e.g., if one master and three slaves are in the network, there are three nodes).

Memory

Manages input/output data, diagnostic information, and settings for the ARIO series.

Memory Map

Rows of data managed individually by couplers and modules or configured by the field network master based on the slave order and settings.

Hot-swap

A function allowing for the replacement of modules in the ARIO unit without shutting down the system's power in case of malfunction.

Bypass Power

Power line supplied to the next module even if a module's body is removed during hot-swap.

Cut-off Power

Power supply line to the next module is cut off when a module's body is removed during hot-swap.

01) This term is not defined in IEC 61158 but is defined by our company. The standard defines this concept as the FieldBus.

02) This term is interpreted in a specific aspect of meaning defined in IEC 61158.

Ordering Information

This is only for reference, the actual product does not support all combinations. For selecting the specified model, follow the Autonics website.

■ Couplers

ARIO - ① ② - ③

① Product type

C: Coupler

② Number of terminal holes

No mark: 12 holes

③ Protocol

EC: EtherCAT

CL: CC-Link ver 2.0

CL1: CC-Link ver 1.1

PN: PROFINET

PB: PROFIBUS

EI: EtherNet/IP

DN: DeviceNet

MT: Modbus/TCP compatible

MR: Modbus/RTU compatible

■ Slim I/O modules

ARIO - ① ② - ③ ④ ⑤

① Product type

S: Slim I/O module

② Number of terminal holes

No mark: 12 holes

1: 16 holes

③ Input/Output signal

DI: Digital input

DO: Digital output

AI: Analog input

AO: Analog output

④ Number of channels

02: 2 channels

04: 4 channels

08: 8 channels

16: 16 channels

⑤ Input/Output specifications

P: PNP

N: NPN

V1: Voltage (± 10 VDC)

V2: Voltage (0 - 10 VDC)

V3: Voltage ($\pm 10 / 0 - 10$ VDC)

C1: Current (0 - 20 mA)

C2: Current (4 - 20 mA)

C3: Current (0 - 20 / 4 - 20 mA)

TC: Thermocouple

RTD: Resistance thermometer

■ Power modules

ARIO - ① ② - ③

① Product type

P: Power module

② Number of terminal holes

No mark: 12 holes

1: 16 holes

③ Power supply (terminal configuration)⁰¹⁾

B: Bus power (V2 + G2 + F2)

F1: Field power (V6 + G2)

F2: Field power (V2 + G6)

M: Bus + Field power (V4 + G4 + F2)

T1: Terminal power (V8 + G4)

T2: Terminal power (V4 + G8)

T3: Terminal power (V16)

T4: Terminal power (G16)

T5: Terminal power (F16)

T6: Terminal power (V8 + G8)

01) V: 24 VDC= or Positive (+),
G: 0 VDC= or Negative (-),
F: Frame Ground

Product Components

■ Couplers

Model	ARIO-C-EC	ARIO-C-CL(1)	ARIO-C-PN	ARIO-C-PB
Product components	Product, instruction manual			
End module	× 1	× 1	× 1	× 1
Communication connector	-	× 1	-	-
Terminating resistance	-	× 2	-	-

Model	ARIO-C-EI	ARIO-C-DN	ARIO-C-MT	ARIO-C-MR
Product components	Product, instruction manual			
End module	× 1	× 1	× 1	× 1
Communication connector	-	× 1	-	× 1
Terminating resistance	-	× 2	-	× 2

■ Slim I/O modules and power modules

- Product
- Instruction manual

Sold Separately

The ARIO couplers and modules consist of terminal, body, and base components. Each connecting component can be replaced as needed, and can be purchased individually. To purchase new parts, check the model name of the product you are using and the model name of the part that can be replaced.

Connectable components

- Terminal
- Body (module)
- Base

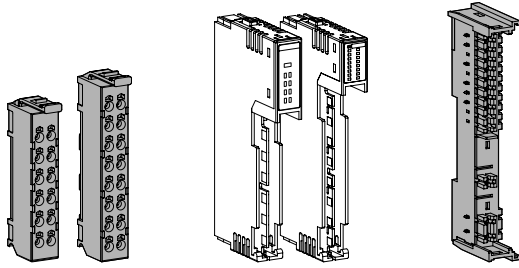

Couplers

Coupler	Terminal model	Base model
ARIO-C-EC	ARIO-TERMINAL-12	ARIO-BASE-C
ARIO-C-CL		
ARIO-C-CL1		
ARIO-C-PN		
ARIO-C-PB		
ARIO-C-EI		
ARIO-C-DN		
ARIO-C-MT		
ARIO-C-MR		

Digital input modules

Module	Terminal model	Body model	Base model
ARIO-S-DI04P	ARIO-TERMINAL-12	ARIO-BODY-S-DI04P	ARIO-BASE-S
ARIO-S-DI04N		ARIO-BODY-S-DI04N	
ARIO-S-DI08P		ARIO-BODY-S-DI08P	
ARIO-S-DI08N		ARIO-BODY-S-DI08N	
ARIO-S1-DI04P	ARIO-TERMINAL-16	ARIO-BODY-S1-DI04P	
ARIO-S1-DI04N		ARIO-BODY-S1-DI04N	
ARIO-S1-DI08P		ARIO-BODY-S1-DI08P	
ARIO-S1-DI08N		ARIO-BODY-S1-DI08N	
ARIO-S1-DI16P		ARIO-BODY-S1-DI16P	
ARIO-S1-DI16N		ARIO-BODY-S1-DI16N	

Digital output modules

Module	Terminal model	Body model	Base model
ARIO-S-DO04P	ARIO-TERMINAL-12	ARIO-BODY-S-DO04P	ARIO-BASE-S
ARIO-S-DO04N		ARIO-BODY-S-DO04N	
ARIO-S-DO08P		ARIO-BODY-S-DO08P	
ARIO-S-DO08N		ARIO-BODY-S-DO08N	
ARIO-S1-DO04P	ARIO-TERMINAL-16	ARIO-BODY-S1-DO04P	
ARIO-S1-DO04N		ARIO-BODY-S1-DO04N	
ARIO-S1-DO08P		ARIO-BODY-S1-DO08P	
ARIO-S1-DO08N		ARIO-BODY-S1-DO08N	
ARIO-S1-DO16P		ARIO-BODY-S1-DO16P	
ARIO-S1-DO16N		ARIO-BODY-S1-DO16N	

Analog input modules

Module	Terminal model	Body model	Base model
ARIO-S-AI02V1	ARIO-TERMINAL-12	ARIO-BODY-S-AI02V1	ARIO-BASE-S
ARIO-S-AI02V2		ARIO-BODY-S-AI02V2	
ARIO-S-AI02C1		ARIO-BODY-S-AI02C1	
ARIO-S-AI02C2		ARIO-BODY-S-AI02C2	
ARIO-S-AI04V1		ARIO-BODY-S-AI04V1	
ARIO-S-AI04V2		ARIO-BODY-S-AI04V2	
ARIO-S-AI04C1	ARIO-TERMINAL-16	ARIO-BODY-S-AI04C1	
ARIO-S-AI04C2		ARIO-BODY-S-AI04C2	
ARIO-S1-AI08V3		ARIO-BODY-S1-AI08V3	
ARIO-S1-AI08C3		ARIO-BODY-S1-AI08C3	

Analog output modules

Module	Terminal model	Body model	Base model
ARIO-S-AO02V1	ARIO-TERMINAL-12	ARIO-BODY-S-AO02V1	ARIO-BASE-S
ARIO-S-AO02V2		ARIO-BODY-S-AO02V2	
ARIO-S-AO02C1		ARIO-BODY-S-AO02C1	
ARIO-S-AO02C2		ARIO-BODY-S-AO02C2	
ARIO-S-AO04V1		ARIO-BODY-S-AO04V1	
ARIO-S-AO04V2		ARIO-BODY-S-AO04V2	
ARIO-S-AO04C1	ARIO-TERMINAL-16	ARIO-BODY-S-AO04C1	
ARIO-S-AO04C2		ARIO-BODY-S-AO04C2	
ARIO-S1-AO08V3		ARIO-BODY-S1-AO08V3	
ARIO-S1-AO08C3		ARIO-BODY-S1-AO08C3	

Temperature input modules

Module	Terminal model	Body model	Base model
ARIO-S-AI04TC	ARIO-TERMINAL-12	ARIO-BODY-S-AI04TC	ARIO-BASE-S
ARIO-S-AI04RTD		ARIO-BODY-S-AI04RTD	
ARIO-S1-AI08TC	ARIO-TERMINAL-16	ARIO-BODY-S1-AI08TC	
ARIO-S1-AI08RTD		ARIO-BODY-S1-AI08RTD	

Bus power modules

Module	Terminal model	Body model	Base model
ARIO-P-B	ARIO-TERMINAL-12	ARIO-BODY-P-B	ARIO-BASE-PBUS

Field power modules

Module	Terminal model	Body model	Base model
ARIO-P-F1	ARIO-TERMINAL-12	ARIO-BODY-P-F1	ARIO-BASE-PIO
ARIO-P-F2		ARIO-BODY-P-F2	

Bus + Field power modules

Module	Terminal model	Body model	Base model
ARIO-P-M	ARIO-TERMINAL-12	ARIO-BODY-P-M	ARIO-BASE-PM

Terminal power modules

Module	Terminal model	Body model	Base model
ARIO-P-T1	ARIO-TERMINAL-12	ARIO-BODY-P-T1	ARIO-BASE-C
ARIO-P-T2		ARIO-BODY-P-T2	
ARIO-P1-T3	ARIO-TERMINAL-16	ARIO-BODY-P1-T3	
ARIO-P1-T4		ARIO-BODY-P1-T4	
ARIO-P1-T5		ARIO-BODY-P1-T5	
ARIO-P1-T6		ARIO-BODY-P1-T6	

Manuals and Software

For proper use of the product, refer to the manuals and be sure to follow the safety considerations and/or detailed precautions in the manuals. Download the manuals and the installation software from the Autonics website.

Reference manuals	Descriptions
Product manual	It contains information for you to setup and install the ARIO Unit. <ul style="list-style-type: none"> • Key features of ARIO Series • Environmental conditions and handling method for installation • Instructions about maintenance, etc.
Coupler manual	It contains information for you to configure and use the coupler in the field network. <ul style="list-style-type: none"> • Communication protocol overview • Hardware information <ul style="list-style-type: none"> : specifications, indicators, connection diagram, and dimensions, etc. • Software information <ul style="list-style-type: none"> : process images, and mapping information, etc.
Module manual	It contains information on the modules provided by Autonics. <ul style="list-style-type: none"> • Hardware information <ul style="list-style-type: none"> : specifications, indicators, connection diagram, and dimensions, etc.
DAQMaster user manual (software)	It contains information and usage guides on ARIO-related functions supported by DAQMaster, the comprehensive device management program. <ul style="list-style-type: none"> • Change properties of the coupler and modules • Module configuration via virtual mode • Check the address map of the Unit • Update the firmware version of the coupler, etc.

Check the Version Compatibility

Before using the product, be sure to verify that the coupler's firmware (software) version is compatible with the module. To do this, follow the instructions below.

If necessary, refer to the DAQMaster user manual to update the coupler's firmware to the latest version.

1. Check the SW version marked on the side of the product. Or,
2. Connect the product to the DAQMaster and check the F/W version in the property window.

Coupler firmware version	Compatible module	Module firmware version
1.14.**	ARIO-S	≧ v 1.00
1.20.**	ARIO-S, ARIO-S1	≧ v 1.00
1.30.**	ARIO-S, ARIO-S1	≧ v 1.00

[Example] Verifying coupler and module versions

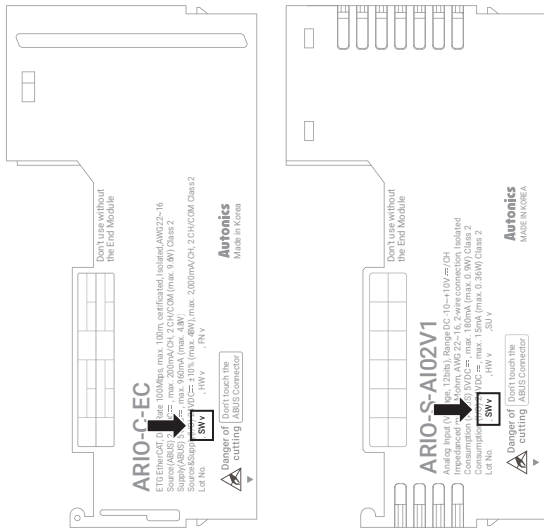

Caution for coupler firmware updates

- The supported update range varies depending on the coupler's firmware version. Refer to the table below to ensure that the firmware update is performed correctly.
- If the coupler's firmware version is **v1.30.**** or higher, be sure to use the latest DAQMaster software version **v3.5.13** or above.

Coupler firmware version	Upgrade range	Downgrade range
1.14.**	≦ v1.20.**	≧ v1.00.**
1.20.**	≦ v1.20.**	≧ v1.00.**
1.30.**	≧ v1.30.**	≧ v1.30.**

Unit Descriptions

For detailed information about each coupler and module, refer to the respective manuals of the couplers and modules.

■ Coupler

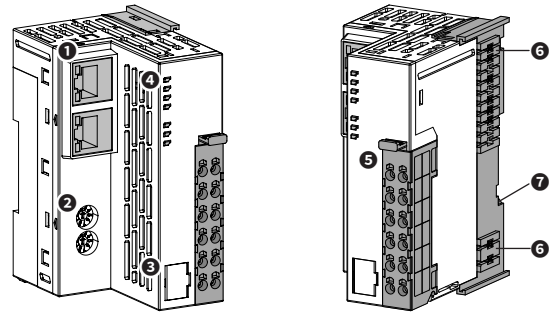

1. (Field network) Communication connector
2. Communication setting rotary switch
3. CONFIG port
4. Power and communication status indicators

5. Power supply terminal
6. Power supply contacts
7. Rail Lock

• The composition of the communication connector and rotary switch

Coupler	Comm. connector	Comm. setting rotary switch
ARIO-C-EC	RJ-45	Not applicable
ARIO-C-CL(1)	5-pin PCB	Decimal rotary switch (data rate, address)
ARIO-C-PN	RJ-45	Hexadecimal rotary switch (address)
ARIO-C-PB	9-pin D SUB	Hexadecimal rotary switch (address)
ARIO-C-EI	RJ-45	Hexadecimal rotary switch (address)
ARIO-C-DN	5-pin PCB	Decimal rotary switch (data rate, address)
ARIO-C-MT	RJ-45	Hexadecimal rotary switch (address)
ARIO-C-MR	5-pin PCB	Hexadecimal rotary switch (address)

■ Module

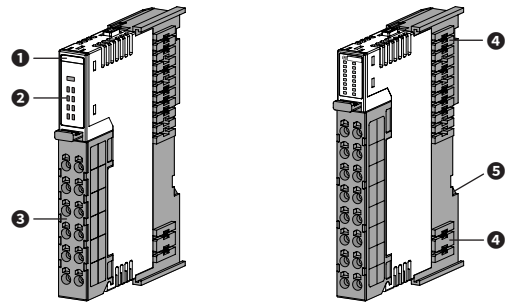

1. Color label for each module
2. Module and channel status indicators
3. Terminal

4. Power supply contacts
5. Rail Lock

• The differentiation of modules based on the color label

Color label	Module	Color label	Module
Green	Digital input module	Purple	Analog output module
Orange	Digital output module	Yellow	Temperature input module
Sky blue	Analog input module	Red	Power module

■ End module

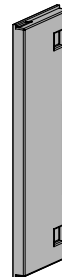

Power Supply and Distribution

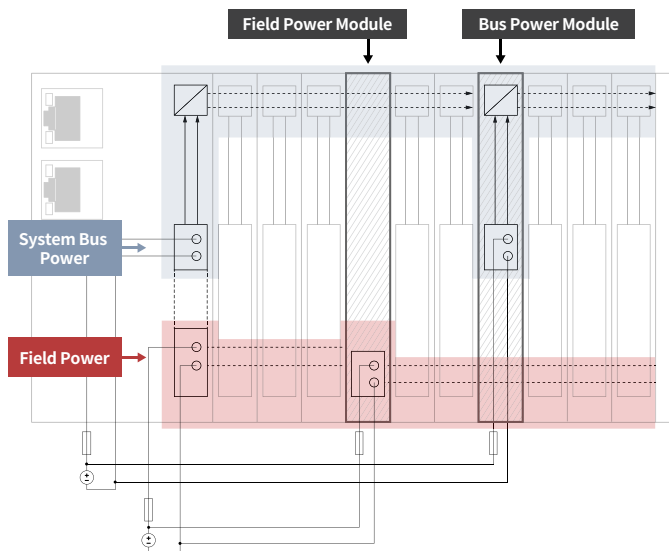

	External power supply	Internal bypass power	Internal cut-off power
Coupler	System bus power, field power	-	System bus power, field power
Bus power module	System bus power	Field power	System bus power
Field power module	Field power	System bus power	Field power

- External power: The power input through the terminals.
- Internal power: The power distributed within the ARIO system through the base.

Power module configurations

Bus power module	Supplies power to the operation and internal communication of the coupler and modules.
Field power module	Supplies power to external devices connected to the modules, such as sensors and actuators.
Terminal power module	Designed to alleviate difficulty due to a lack of terminals when connecting the ferrules, facilitating more efficient wiring operation.

Isolation

Isolation	Between (field network) communication connector and internal control circuit.
	Between external bus power and external field power circuits.
Non-Isolation	Between external bus power and internal control circuits.
	Between external bus power and external control circuits.
	Between internal bus power and internal control circuits.

Installation Requirements



- 01. Before installing the product, be sure to check and comply with the environmental conditions listed in the specifications of the coupler and module manuals.**
The product functionality may be limited depending on the installation environment.
- 02. This product may generate heat even during simple operation, but unless in special cases, it does not significantly affect product operation.**

Before installing the product, be sure to check the installation components and environmental conditions listed below.

The components of ARIO system

Components	Descriptions
DAQMaster software	- Supports configuration and virtual mode for the coupler and module
Coupler	- The slave device for the field network communication - Manages the module settings and memory map
Slim I/O module	- Transfers the input/output signals from sensors and actuators - Supports the hot-swap function for maintenance
Power module	- Supplies power to the couplers, modules, sensors and actuators - Provides additional terminal holes during wiring - Supports the hot-swap function for maintenance
End module	- Installed at the end of the ARIO unit, preventing the base exposure.
End plate	- Used to firmly fix the ARIO unit installed on a DIN rail, recommended to be purchased commercially. (recommended installation height: ≤ 15 mm)
Tools	- A non-conductive flat-head screwdriver (≤ 3 mm width) - Wires and ferrule terminals, etc.
DIN rail	- 35×7.5 mm or 35×15 mm

The configuration of ARIO unit

- The ARIO unit is designed to be mounted on a DIN rail. Therefore, adhere to the recommended distances and directions during installation.
- When configuring the ARIO unit, install the coupler on the far left first, and then install the modules to the right of the coupler in sequence.
- The number of modules that can be connected to a coupler is up to 64 or 32, with the corresponding maximum connection length being 768 mm or 384 mm, excluding the length of the coupler and end modules. Since each coupler model supports a different number of module connections, refer to the 'Specifications'.
- When expanding modules, be sure to consider the power consumption of sensors and actuators connected to the coupler and power module. When connecting only one coupler, connect the bus power and field power modules every 8 digital input/output modules, and every 4 analog input/output or temperature input modules.
- Do not connect temperature input modules directly adjacent to both sides of a power module.
- For temperature input modules, temperature errors may occur due to line resistance.
- Also, check the recommended module combination provided by DAQMaster's virtual mode function.
- To prevent exposure of the base, device damage, and risk of electric shock, be sure to install the end module to the right of the last module.

Installation distance

- Ensure a minimum installation distance and space as shown in the figure below to minimize interference between the ARIO unit and surrounding devices and allow for effective heat dissipation.
- Design the ARIO unit with an intake-exhaust structure to allow heat generated from the unit to escape from the bottom to the top, and install an air exhaust fan at the top for air cooling.
- For temperature input module: Install in a location where it is not directly exposed to airflow, considering the installation distance.

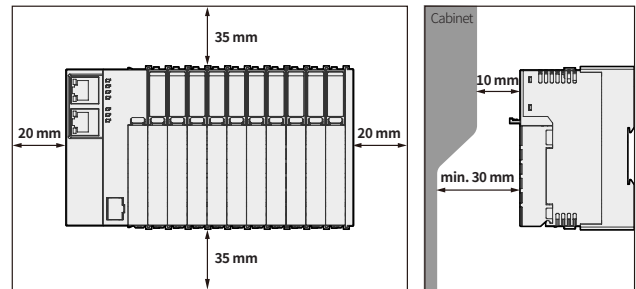

Installation direction

- For effective heat dissipation and stable operation, install the ARIO unit in a horizontal orientation with the coupler positioned on the far left. To maintain the ARIO unit securely, firmly fix it with end modules and end plates.

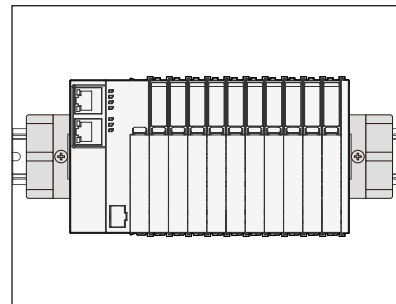

Wiring Requirements



01. Use the wires made of copper conductors with a temperature rating of 60 °C.
02. Do not connect or disconnect the wires at the terminals while the product is in operation.
03. Use the tools made of non-conductive materials when working on wiring operation.
04. Organize the cables in such a way to avoid excessive bending or tangling to minimize stress.

Errors in wiring methods or product malfunctions may result in personal injury and economic loss. Follow these instructions carefully.

Compliance with communication cable

Use of standardized products

Use the connectors, cables, and other components that have been approved by the Field Network Association and certified by organizations such as UL, KC, etc.

Compliance with communication cable length (node spacing)

Install in compliance with the minimum and maximum distances and the spacing between nodes defined for each communication speed by the Field Network standards.

Prohibition of T-shaped branching

To ensure stable communication, do not use T-shaped branching when connecting cables. The T-shaped branching can cause noise-induced interference and disruption in communication signals.

Prohibition of loop structure

When connecting and organizing cables, avoid forming loops and maintain a linear and gentle curve shape. This ensures the stability of data transmission.

Segmentation

Differentiate control areas with different functions or locations into independent segments for management. This prevents issues from spreading to other segments, maintaining a stable communication environment. The size of the segments defined by the Field Network standards may vary, such as units of 16 nodes or 32 nodes. For serial communications, install one repeater per segment.

Use of hubs

The use of hubs or switch hubs is recommended when extending communication cables. (The switch Hub: for handling network traffic and parallel data transmission)

Installation of ferrite cores

Install ferrite cores about 10 cm away from communication connectors and terminals to minimize environmental noise. For the ARIO units, products like Laird's 28A5776-0A2 or those meeting equivalent performance are recommended.

The installation method for each ferrite core may vary depending on the equipment and type of cable used, so refer to the manufacturer's instructions or manual of the equipment for the installation.

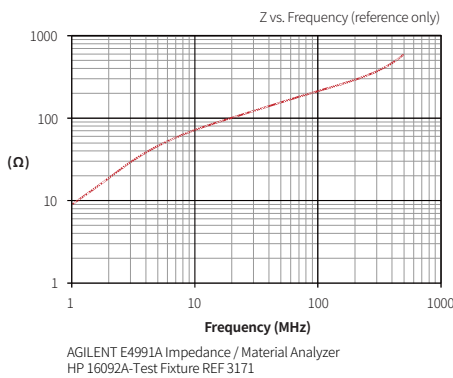

Impedance (Z)

Frequency (MHz)	Standard value (Ω)	Minimum value (Ω)
25	115	-
100	210	168
300	360	-

Terminals specifications



Depending on the installation environment, the use of solid wire and other materials outside the permissible range is possible, but you must strictly adhere to the specifications below.

Failure to this instruction may result in personal injury and economic loss due to the product malfunction.

Wiring method	Screwless type
Permitted parts	Pin connector, pin terminal
Wiring specifications	AWG 22-16 (recommended: AWG 18)
Wiring insertion length	8 to 12 mm (recommended: 10 mm)
Terminal permitted voltage	≤ 230 VAC~
Terminal permitted current	≤ 2000 mA

Ferrule terminal specifications

- Be sure to use the UL-approved ferrule terminals.
- For the temperature input modules: Be sure to use wiring and ferrule terminals suitable for temperature sensors.

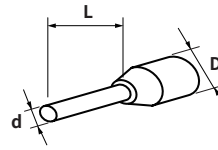

[Recommended wiring: AWG 18]

L	d	D
10 mm	Ø1	Ø3

[Wiring: AWG 22-16]

L	d	D
8 to 12 mm	Ø0.6 to Ø1.3	Ø3

Separating Terminal Cables

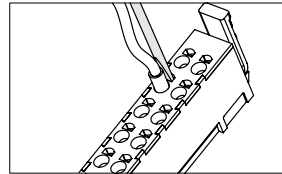

- Insert a non-conductive screwdriver, no wider than 3 mm, into the groove on the terminal, facilitating to disconnect and release the cable connected to the hole.

Grounding and Shielding

Grounding

- Refer to the connection diagrams in the coupler and module manuals for grounding terminals.
- When installing on the DIN rail, ground through the housing frame, such as the case.
- A grounding structure is provided using parts with a metal spring structure assembled at the bottom of the base.

Shielding

- The shielded cables can minimize the impact from external interference or noise. The shielding work is recommended.
- The communication cables: To improve the signal quality of the communication lines, the use of shielded/clamped cables is recommended.
- The power and input/output cables: To improve safety of grounding and noise reduction, the use of shielded/clamped cables is recommended.

Shielding applications

Refer to the example below for shielding applications, but ensure not to create a closed circuit. Connecting the shield to other circuits may lead to it being a significant source of noise.

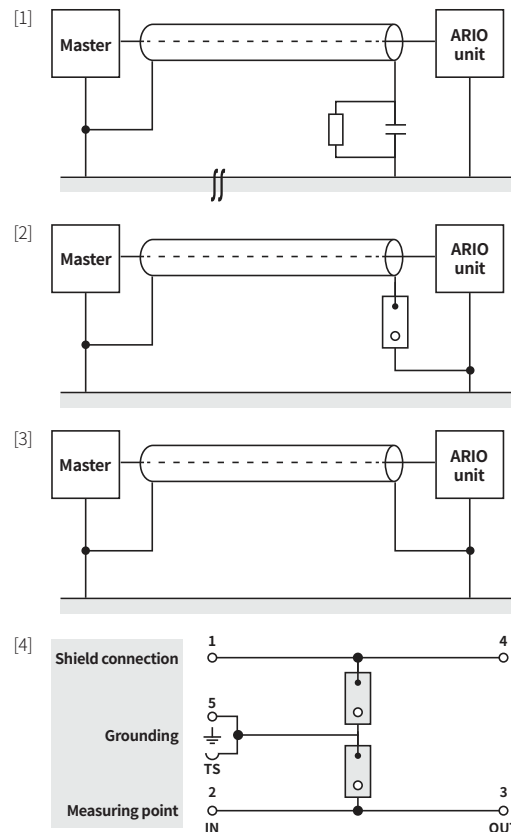

Installing on a DIN rail

The installation of the ARIO unit on a DIN rail starts from the left side, based on the horizontal orientation.

• (End plate) → Coupler → Module → End module → (End plate)

■ Installation process

01. Use the prepared screwdriver to pull down the Rail Lock located at the back of the coupler.

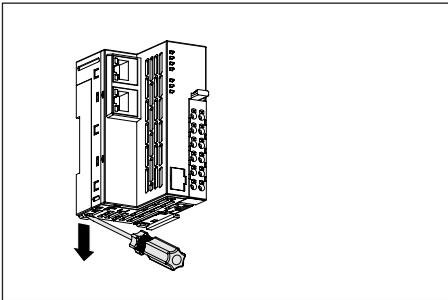

02. Hook the Rail Lock on the back of the coupler onto the DIN rail.

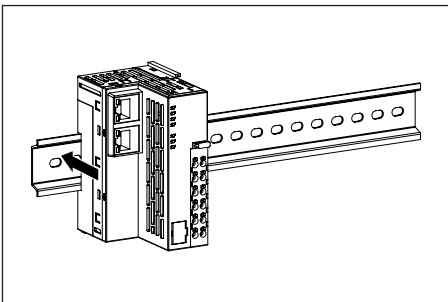

03. Push the module in the direction of the DIN rail. Ensure that the bases of the coupler and module interlock properly.

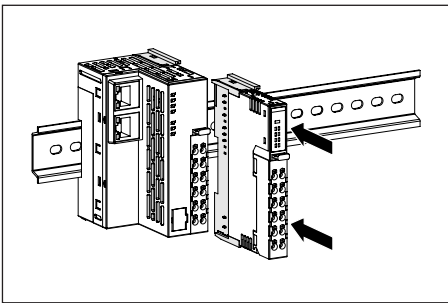

04. Mount the end module on the right side of the last module.

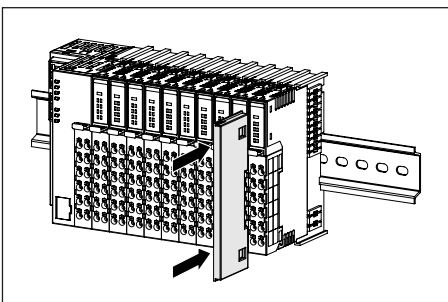

05. Use the screwdriver to push up the Rail Lock again to secure the unit in place. To firmly fix the unit, mount end plates on both sides of the unit.

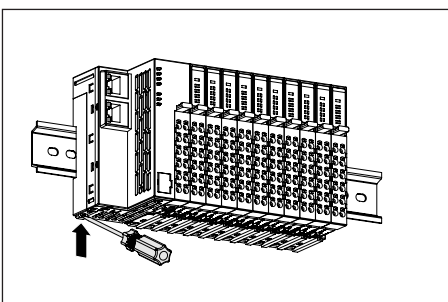

Maintenance

■ Hot-swap

The hot-swap function allows the replacement of terminal and body parts of a module while the system or device is operating. It facilitates product upgrades or maintenance without shutting down the system.

Be sure to consider the following instructions during hot-swap operations to avoid personal injury or damage to the product and system.



01. Always turn off the power before replacing the base.
 02. Do not touch the connector part of the base while the product is operating.
 03. Use the same type of parts when replacing components.
 04. Be aware that input/output modules and power modules have different bases.
 05. If the terminal, body, or base is disassembled, the internal circuit may be exposed to the external environment. Do not operate in this disassembled state for an extended period.
 06. Do not disassemble the product until the module causing the malfunction, failure, or error has been replaced, as long as it does not affect the entire system.
- There is a risk of resetting module settings due to power loss.

■ Assembling and disassembling the terminal

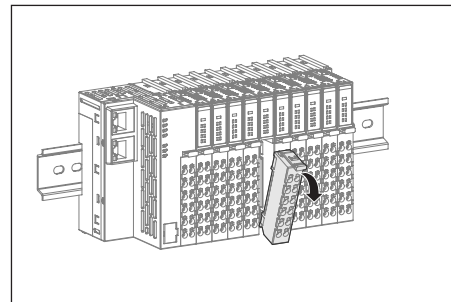

- Disassembly: Press the lever at the top of the terminal and pull it forward to detach it.
- Assembly: Align the lower part of the terminal with the lower part of the body and push to insert.

■ Assembling and disassembling the body

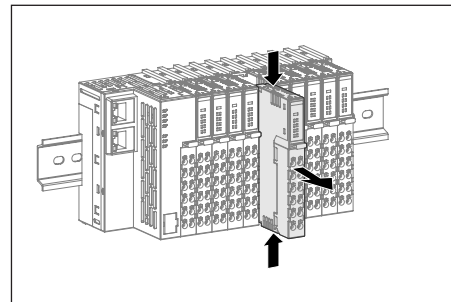

- Disassembly: Simultaneously press both levers at the top/bottom of the body and pull it forward to detach.
- Assembly: Slide it in parallel to connect it with the base.

■ Assembling and disassembling the base

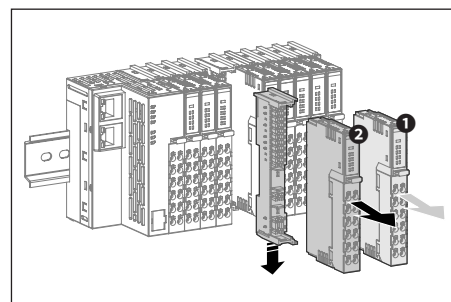

- Disassembly: To replace the base of module ②, disassemble the body of module ① located to its right. And pull down the Rail Lock of module ② to remove the base and body from the DIN rail, then disassemble the body.
- Assembly: Combine the new base with the body and place them on the DIN rail. Secure it using the Rail Lock. And then slide the body of module ① in parallel to connect it to the base.

Specifications: Analog Input/Output Modules

General specifications

Transmission speed (ABUS)	4 Mbps
Protection circuit	It depends on the module type.
Analog input module	Reverse field power protection circuit
Analog output module	Reverse field power protection circuit
Insulation	I/O to internal circuit: photocoupler insulated / Between channels: non-insulated
Indicator	Module status indicator (green, red), channel status indicator (green)
Material	Terminal: PBT, body: PC, base: PA6, POM
Installation method	DIN rail 35 mm
Unit weight (packaged)	≈ 75 g (≈ 108 g)

Analog input modules

Model	ARIO-S-AI□V1	ARIO-S-AI□V2
Input specifications	Voltage input	
Channels	2-CH / 4-CH	
Data size	4-byte / 8-byte	
Input range	±10 VDC≐	0 to 10 VDC≐
Allowable limit range	±12 VDC≐	-1.0 to 11 VDC≐
Resolution	12-bit	
Accuracy	At room temperature: ±0.3% F.S / Outside room temperature: ±0.6% F.S	
Input impedance	≥ 1 MΩ	
Sensor connection method	2-wire / 2-wire + FG	
Power consump. (ABUS)	≤ 180 mA @ 5 VDC≐ (≤ 0.9 W)	
Power consump. (Field)	≤ 15 mA @ 24 VDC≐ (≤ 0.36 W)	

Model	ARIO-S1-AI08V3
Input specifications	Voltage input
Channels	8-CH
Data size	16-byte
Input range	±10 VDC≐ / 0 to 10 VDC≐ (default)
Allowable limit range	±11 VDC≐ / -0.5 to 10.5 VDC≐
Resolution	16-bit
Accuracy	At room temperature: ±0.1% F.S / Outside room temperature: ±0.5% F.S
Input impedance	≥ 550 kΩ
Sensor connection method	2-wire
Power consump. (ABUS)	≤ 100 mA @ 5 VDC≐ (≤ 0.5 W)
Power consump. (Field)	≤ 0 mA @ 24 VDC≐ (≤ 0.0 W)

Model	ARIO-S-AI□C1	ARIO-S-AI□C2
Input specifications	Current input	
Channels	2-CH / 4-CH	
Data size	4-byte / 8-byte	
Input range	0 to 20 mA	4 to 20 mA
Allowable limit range	0 to 22 mA	2.4 to 21.6 mA
Resolution	12-bit	
Accuracy	At room temperature: ±0.3% F.S / Outside room temperature: ±0.6% F.S	
Input impedance	≤ 250 Ω	
Sensor connection method	2-wire / 2-wire + FG	
Power consump. (ABUS)	≤ 180 mA @ 5 VDC≐ (≤ 0.9 W)	
Power consump. (Field)	≤ 15 mA @ 24 VDC≐ (≤ 0.36 W)	

Model	ARIO-S1-AI08C3
Input specifications	Current input
Channels	8-CH
Data size	16-byte
Input range	0 to 20 mA / 4 to 20 mA (default)
Allowable limit range	0 to 21 mA / 3.2 to 20.8 mA
Resolution	16-bit
Accuracy	At room temperature: ±0.1% F.S / Outside room temperature: ±0.5% F.S
Input impedance	≤ 150 Ω
Sensor connection method	2-wire
Power consump. (ABUS)	≤ 100 mA @ 5 VDC≐ (≤ 0.5 W)
Power consump. (Field)	≤ 0 mA @ 24 VDC≐ (≤ 0.0 W)

Analog output modules

Model	ARIO-S-AO□V1	ARIO-S-AO□V2
Output specifications	Voltage output	
Channels	2-CH / 4-CH	
Data size	4-byte / 8-byte	
Output range	±10 VDC≐	0 to 10 VDC≐
Resolution	12-bit	
Accuracy	At room temperature: ±0.3% F.S / Outside room temperature: ±0.6% F.S	
Load resistance	≥ 5 kΩ	
Actuator connection method	2-wire / 2-wire + FG	
Power consump. (ABUS)	≤ 180 mA @ 5 VDC≐ (≤ 0.9 W)	
Power consump. (Field)	≤ 15 mA @ 24 VDC≐ (≤ 0.36 W)	

Model	ARIO-S1-AO08V3
Output specifications	Voltage output
Channels	8-CH
Data size	16-byte
Output range	±10 VDC≐ / 0 to 10 VDC≐ (default)
Resolution	14-bit
Accuracy	At room temperature: ±0.1% F.S / Outside room temperature: ±0.5% F.S
Load resistance	≥ 5 kΩ
Actuator connection method	2-wire
Power consump. (ABUS)	≤ 70 mA @ 5 VDC≐ (≤ 0.35 W)
Power consump. (Field)	≤ 55 mA @ 24 VDC≐ (≤ 1.32 W)

Model	ARIO-S-AO□C1	ARIO-S-AO□C2
Output specifications	Current output	
Channels	2-CH / 4-CH	
Data size	4-byte / 8-byte	
Output range	0 to 20 mA	4 to 20 mA
Resolution	12-bit	
Accuracy	At room temperature: ±0.3% F.S / Outside room temperature: ±0.6% F.S	
Load resistance	≤ 350 Ω	
Actuator connection method	2-wire / 2-wire + FG	
Power consump. (ABUS)	≤ 100 mA @ 5 VDC≐ (≤ 0.5 W)	
Power consump. (Field)	≤ 60 mA @ 24 VDC≐ (≤ 1.44 W)	

Model	ARIO-S1-AO08C3
Output specifications	Current output
Channels	8-CH
Data size	16-byte
Output range	0 to 20 mA / 4 to 20 mA (default)
Resolution	14-bit
Accuracy	At room temperature: ±0.1% F.S / Outside room temperature: ±0.5% F.S
Load resistance	≤ 350 Ω
Actuator connection method	2-wire
Power consump. (ABUS)	≤ 70 mA @ 5 VDC≐ (≤ 0.35 W)
Power consump. (Field)	≤ 140 mA @ 24 VDC≐ (≤ 3.36 W)

Specifications: Temperature Input Modules

■ General specifications

Transmission speed (ABUS)	4 Mbps
Protection circuit	Reverse field power protection circuit
Insulation	I/O to internal circuit: photocoupler insulated / Between channels: non-insulated
Indicator	Module status indicator (green, red), channel status indicator (green)
Material	Terminal: PBT, body: PC, base: PA6, POM
Installation method	DIN rail 35 mm
Unit weight (packaged)	≈ 75 g (≈ 108 g)

■ Thermocouple (TC) input modules

Model	ARIO-S-AI04TC	ARIO-S1-AI08TC
Channels	4-CH	8-CH
Data size	8-byte	16-byte
Sensor type	K (default), J, E, T, B, R, S, N, C / W5, G / W, L, U, PL II	
Sensor connection method	2-wire	
Resolution	16-bit	
Accuracy	±0.2% F.S (at room temperature: 23 °C ±5 °C)	
Temperature range	-200 to 2300 °C	
Sampling rate	50 msec/CH	
Power consump. (ABUS)	≤ 180 mA @ 5 VDC≐ (≤ 0.9 W)	≤ 140 mA @ 5 VDC≐ (≤ 0.7 W)
Power consump. (Field)	≤ 15 mA @ 24 VDC≐ (≤ 0.36 W)	≤ 20 mA @ 24 VDC≐ (≤ 0.48 W)

■ Resistance thermometer (RTD) input modules

Model	ARIO-S-AI04RTD	ARIO-S1-AI08RTD
Channels	4-CH	8-CH
Data size	8-byte	16-byte
Sensor type	Pt50, Pt100 (default), Pt1000 / JPt50, JPt100, JPt1000 / Ni100, Ni120, Ni1000 / Cu50, Cu100	
Sensor connection method	3-wire	2-wire
Resolution	16-bit	
Accuracy	Pt, JPt: ±0.2% F.S / Ni: ±0.3% F.S / Cu: ±0.5% F.S (at room temperature: 23 °C ±5°C)	
Temperature range	-200 to 650 °C	
Sampling rate	50 msec/CH	
Power consump. (ABUS)	≤ 180 mA @ 5 VDC≐ (≤ 0.9 W)	≤ 120 mA @ 5 VDC≐ (≤ 0.6 W)
Power consump. (Field)	≤ 15 mA @ 24 VDC≐ (≤ 0.36 W)	≤ 20 mA @ 24 VDC≐ (≤ 0.48 W)

Specifications: Power Modules

■ General specifications

Transmission speed (ABUS)	4 Mbps
Protection circuit ⁰¹⁾	Reverse bus power protection circuit, Bus power short circuit protection circuit
Indicator ⁰²⁾	Power status indicator (green)
Material	Terminal: PBT, body: PC, base: PA6, POM
Installation method	DIN rail 35 mm
Unit weight (packaged)	≈ 75 g (≈ 108 g)

01) Applicable models: ARIO-P-B, ARIO-P-M

02) ARIO-P1-T5 model: Does not support the indicator.

■ Bus power modules

Model	ARIO-P-B
Number of terminal holes	12 holes
System bus power	≤ 2 A @ 24 VDC≐ (≤ 48 W)/hole, (up to 4 A)
Internal system bus power	≤ 1.5 A @ 5 VDC≐ (≤ 7.5 W)

■ Field power modules

Model	ARIO-P-F1	ARIO-P-F2
Number of terminal holes	12 holes	
Field power configuration	24 VDC≐ × 6 0 VDC≐ × 2	24 VDC≐ × 2 0 VDC≐ × 6
Field power	≤ 2 A @ 24 VDC≐ (≤ 48 W)/hole, (up to 4 A)	
Internal field power	≤ 2 A @ 24 VDC≐ (≤ 48 W)/hole, (up to 4 A)	

■ Bus + Field power modules

Model	ARIO-P-M
Number of terminal holes	12 holes
System bus power	≤ 2 A @ 24 VDC≐ (≤ 48 W)/hole, (up to 4 A)
Internal system bus power	≤ 1.5 A @ 5 VDC≐ (≤ 7.5 W)
Field power	≤ 2 A @ 24 VDC≐ (≤ 48 W)/hole, (up to 4 A)
Internal field power	≤ 2 A @ 24 VDC≐ (≤ 48 W)/hole, (up to 4 A)

■ Terminal power modules

Model	ARIO-P-T1	ARIO-P-T2
Number of terminal holes	12 holes	
Field power configuration	24 VDC≐ × 8 0 VDC≐ × 4	24 VDC≐ × 4 0 VDC≐ × 8
Field output power	≤ 2 A @ 24 VDC≐ (≤ 48 W)/hole, (up to 4 A)	

Model	ARIO-P1-T3	ARIO-P1-T4	ARIO-P1-T5	ARIO-P1-T6
Number of terminal holes	16 holes			
Field power configuration	24 VDC≐ × 16	0 VDC≐ × 16	F.G. × 16	24 VDC≐ × 8 0 VDC≐ × 8
Field output power	≤ 2 A @ 24 VDC≐ (≤ 48 W)/hole, (up to 4 A)			

Specifications: Parameters (DAQMaster)

■ Input Filter

Adjusts the input data filter for analog signals (voltage, current, temperature).

• Supported modules: Analog input/output modules, temperature input modules

Models	Sampling range
ARIO-S1-AI08V3/C3	Disable (default), 2, 4, 8, 16, 32, 64, 128, 256, 512, 1024
ARIO-S1-AI08TC/RTD	

■ Multiple Range

Allows setting the input/output range for voltage and current.

• Supported modules: Analog input/output modules

Models	Input/Output range
ARIO-S1-AI/AO08V3	±10 VDC \equiv / 0 to 10 VDC \equiv (default)
ARIO-S1-AI/AO08C3	0 to 20 mA / 4 to 20 mA (default)

■ Input Type

Allows setting the type of temperature sensor.

• Supported modules: Temperature input modules

Models	Type of temperature sensors
ARIO-S-AI04TC	K (default), J, E, T, B, R, S, N, C / W5, G / W, L, U, PL II
ARIO-S1-AI08TC	
ARIO-S-AI04RTD	Pt50, Pt100 (default), Pt1000 / JPt50, JPt100, JPt1000 / Ni100, Ni120, Ni1000 / Cu50, Cu100
ARIO-S1-AI08RTD	

Specifications: Environmental Conditions

Insulation resistance	≥ 100 MΩ (500 VDC \equiv megger)
Dielectric strength	Between the charging part and the case : 1000 VAC \sim 50 / 60 Hz for 1 min
Noise immunity	±500 VDC \equiv the square wave noise (pulse width: 1 μs) by the noise simulator
Vibration	0.7 mm double amplitude at frequency of 10 to 55 Hz in each X, Y, Z direction for 1 hour
Vibration (malfunction)	0.5 mm double amplitude at frequency of 10 to 55 Hz in each X, Y, Z direction for 10 min
Shock	300 m/s ² (\approx 30 G) in each X, Y, Z direction for 3 times
Shock (malfunction)	100 m/s ² (\approx 10 G) in each X, Y, Z direction for 3 times
Ambient temperature	-10 to 55 °C, storage: -25 to 70 °C (no freezing or condensation)
Ambient humidity	35 to 85 %RH, storage: 35 to 85 %RH (no freezing or condensation)
Protection rating	IP20 (IEC standard)

Specifications: Certifications

Certification	
---------------	---

01) Certification attainment may vary depending on the model. Check the certification on the Autonics website.