

# Laser Displacement Sensor Communication Converter



## BD-C Series PRODUCT MANUAL

**For your safety, read and follow the considerations written in the instruction manual, other manuals and Autronics website.**

The specifications, dimensions, etc are subject to change without notice for product improvement. Some models may be discontinued without notice.

### Features

- Supports both RS232C and RS485 communication in one device  
: Separate ports for RS232C and RS485
- Connect up to 8 amplifier units
- Can be powered directly by amplifier units without additional wiring
- Support for dedicated device management software (atDisplacement)  
: Batch parameter settings with save/load function  
: Monitor measured values and outputs in real-time
- Set communication speed and addresses using DIP switch without connecting to host devices

※ Sensor head model BD-300/600 supports only over 5.0 firmware version of the amplifier unit (BD-A1).

### Safety Considerations

- Observe all 'Safety Considerations' for safe and proper operation to avoid hazards.
- ⚠ symbol indicates caution due to special circumstances in which hazards may occur.

**⚠ Warning** Failure to follow instructions may result in serious injury or death

- 01. Fail-safe device must be installed when using the unit with machinery that may cause serious injury or substantial economic loss.** (e.g. nuclear power control, medical equipment, ships, vehicles, railways, aircraft, combustion apparatus, safety equipment, crime/disaster prevention devices, etc.)  
Failure to follow this instruction may result in personal injury, economic loss or fire.
- 02. Do not use the unit in the place where flammable/explosive/corrosive gas, high humidity, direct sunlight, radiant heat, vibration, impact or salinity may be present.**  
Failure to follow this instruction may result in explosion or fire.
- 03. Do not disassemble or modify the unit.**  
Failure to follow this instruction may result in fire.
- 04. Do not connect, repair, or inspect the unit while connected to a power source.**  
Failure to follow this instruction may result in fire.
- 05. Check 'Connections' before wiring.**  
Failure to follow this instruction may result in fire.

**⚠ Caution** Failure to follow instructions may result in injury or product damage

- 01. Use the unit within the rated specifications.**  
Failure to follow this instruction may result in fire or product damage.
- 02. Use a dry cloth to clean the unit, and do not use water or organic solvent.**  
Failure to follow this instruction may result in fire.

### Cautions during Use

- Follow instructions in 'Cautions during Use'. Otherwise, it may cause unexpected accidents.
- Do not install where strong magnetic or electric field exist. Otherwise, the resolution may be adversely affected.
- Wire as short as possible and keep away from high voltage lines or power lines, to prevent surge and inductive noise.
- For the optimized performance, it is recommended to measure after 30 minute from supplying power.
- When detecting with the maximum sensitivity, an error may occur depending on each characteristic deviation.
- It is recommended to use Autronics communication converter. Please use twisted pair wire, which is suitable for RS485 communication.
- This unit may be used in the following environments.
  - Indoors (in the environment condition rated in 'Specifications')
  - Altitude max. 2,000 m
  - Pollution degree 3
  - Installation category II

### Proper Usage

Before using this communication converter unit, depending on the usage environment, keep following items handy. Visit our web site ([www.autonics.com](http://www.autonics.com)) to download.

- atDisplacement program, manual
- BD Series manual
- Communication converter SCM Series Driver, instruction manual

## Manual

For the detail information and instructions, please refer to the manual, and be sure to follow cautions written in the technical descriptions (catalog, website). Visit our website ([www.autonics.com](http://www.autonics.com)) to download manuals.

## Software

Download the installation file and the manuals from the Autonics website.

### ■ atDisplacement

atDisplacement is a PC software for BD series laser displacement sensors. It is available for parameter setting, monitoring and data management. Visit our website ([www.autonics.com](http://www.autonics.com)) to download the user manual and the program.

## Product Composition

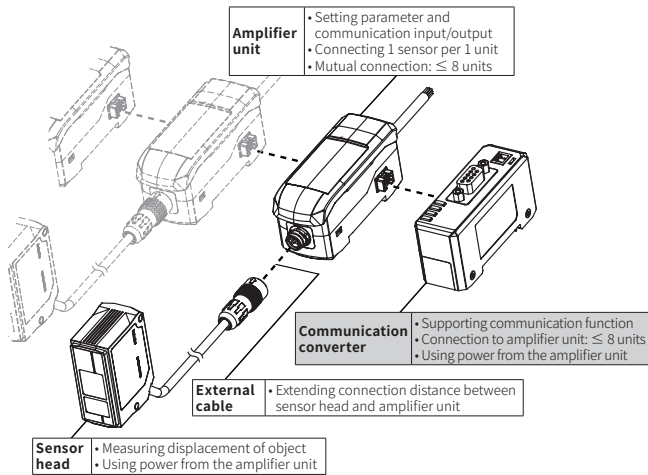

## Specifications

|                               |   |
|-------------------------------|---|
| <b>Model</b>                  | BD-CRS  |
| <b>Supported amplifier</b>    | Amplifier unit (BD-A1) <sup>01)</sup>   |
| <b>Power supply</b>           | From the amplifier unit (BD-A1) (12 - 30 VDC⇒)  |
| <b>Power Consumption</b>      | ≤ 2.3 W   |
| <b>Communication Protocol</b> | Modbus RTU  |
| <b>Connection type</b>        | RS-232C, RS-485   |
| <b>Communication speed</b>    | 9600, 19200, 38400, 115200 bps (default)  |
| <b>Function</b>               | Executes every BD-Series feature, sets parameter and real-time monitoring by external device (Master) |
| <b>Ambient temperature</b>    | -10 to 50 °C, Storage: -15 to 60 °C (no freezing or condensation)                                     |
| <b>Ambient humidity</b>       | ≤ 85%RH, Storage: ≤ 85%RH (no freezing or condensation)   |
| <b>Vibration</b>              | 1.5 mm amplitude at frequency of 10 to 55 Hz in each X, Y, Z direction for 2 hours                    |
| <b>Shock</b>                  | 300 m/s <sup>2</sup> (≈ 50 G) in each X, Y, Z direction for 3 times                                   |
| <b>Protection structure</b>   | IP40 (IEC standard)   |
| <b>Material</b>               | Case: PC  |
| <b>Accessory</b>              | Side connector, Connector for RS485   |
| <b>Sold separately</b>        | Communication converter: SCM Series   |
| <b>Certification</b>          | CE, RoHS, REACH, ENEC, ETL  |
| <b>Unit weight (packaged)</b> | ≈ 49 g (≈ 91 g)   |

01) Communication converter (BD-C) firmware 5.0 and later only supports amplifier unit (BD-A1) firmware 5.0 and later.

## Dimensions

• Unit: mm, For the detailed drawings, follow the Autonics website.

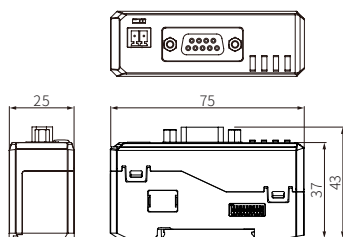

## Unit Descriptions

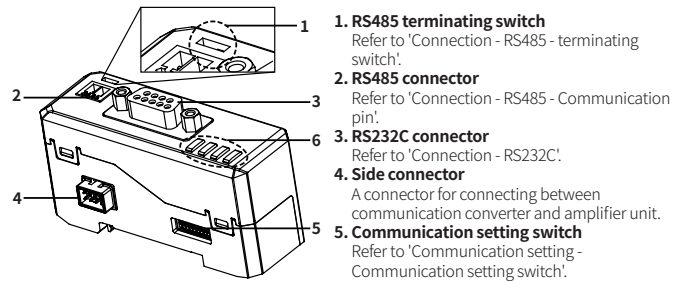

- RS485 terminating switch**  
Refer to 'Connection - RS485 - terminating switch'.
- RS485 connector**  
Refer to 'Connection - RS485 - Communication pin'.
- RS232C connector**  
Refer to 'Connection - RS232C'.
- Side connector**  
A connector for connecting between communication converter and amplifier unit.
- Communication setting switch**  
Refer to 'Communication setting - Communication setting switch'.

### 6. Status Indicator

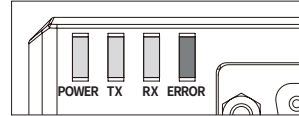

| Display | Color | Name                 | Status | Description           |
|---------|-------|----------------------|--------|-----------------------|
| POWER   | green | Power                | On     | Power is supplied.    |
| TX      | green | Communication output | Flash  | Signal is outputting. |
| RX      | green | Communication input  | Flash  | Signal is inputting.  |
| ERROR   | red   | Communication error  | Off    | Operation is normal.  |

## Connections

### ■ RS232C

• When connecting BD-C to external device, use D-SUB 9 pin cable.

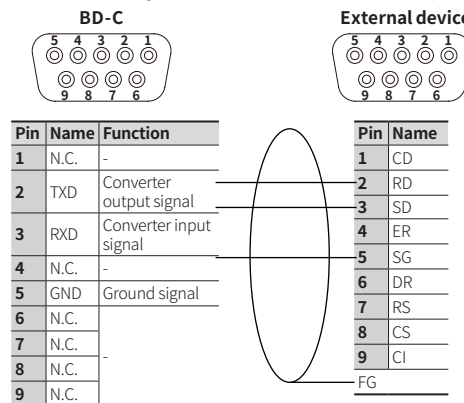

### ■ RS485

#### Communication pin

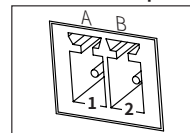

| Pin | Name | Function       |
|-----|------|----------------|
| 1   | A(+) | RS485 + signal |
| 2   | B(-) | RS485 - signal |

#### Terminating switch



Set the switch to 'RT' when the communication converter is connected to the terminal of RS485 communication connection, and set to 'OFF' when it is in the middle of the communication connection.

## Display when Power is ON

Only supported on firmware 5.1 or higher. When power is ON, display the major version and then minor version. Combination of status indicator TX(2<sup>1)</sup>, RX(2<sup>1</sup>) and ERROR(2<sup>1</sup>).

## Error

| Status Indicator | Causes  | Troubleshooting  |
|------------------|---|--|
| POWER            | Off<br>Power is not supplied.   | After checking the connection between Comm. converter and amplifier unit correctly, reconnect the device.                |
| TX               | Off<br>Signal is not outputting.  | After checking the connection between Comm. converter and external device correctly, reconnect the device.               |
| RX               | Off<br>Signal is not inputting.   | After checking the connection between Comm. converter and external device correctly, reconnect the device.               |
| ERROR            | On<br>Connection is bad between communication converter and amplifier unit.       | After checking the connection between Comm. converter and amplifier unit correctly, reconnect the device.                |
|                  | Flash<br>Communication is bad between communication converter and amplifier unit. | Apply noise prevention to Comm. converter and amplifier unit.  |
| TX→RX→ERROR      | Flash twice in order<br>Firmware version incompatible <sup>01)</sup>              | Check the firmware version and needs to update to compatible version. Please contact customer service center for update. |

01) Only supported on firmware 5.1 or higher.

## Communication Setting

### Communication setting switch

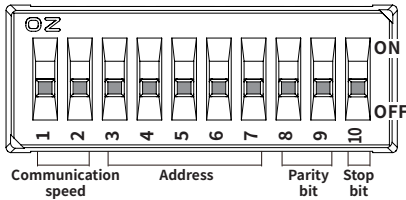

#### Switch 1, 2: Communication speed

| 1   | 2   | Communication speed |
|-----|-----|---------------------|
| ON  | ON  | 9,600 bps           |
| OFF | ON  | 19,200 bps          |
| ON  | OFF | 38,400 bps          |
| OFF | OFF | 115,200 bps         |

#### Switch 3 to 7: Address

| Switch No.   | 3     | 4     | 5     | 6     | 7     | Address   |
|--------------|-------|-------|-------|-------|-------|---|
| Binary digit | $2^4$ | $2^3$ | $2^2$ | $2^1$ | $2^0$ | Address=switch3×2 <sup>4</sup> +switch4×2 <sup>3</sup> +switch5×2 <sup>2</sup> +switch6×2 <sup>1</sup> +switch7×2 <sup>0</sup> +1 |
| OFF = 0      |       |       |       |       |       |   |
| ON = 1       |       |       |       |       |       |   |
| Address 1    | OFF   | OFF   | OFF   | OFF   | OFF   | 1=0×2 <sup>4</sup> +0×2 <sup>3</sup> +0×2 <sup>2</sup> +0×2 <sup>1</sup> +0×2 <sup>0</sup> +1                                     |
| Address 2    | OFF   | OFF   | OFF   | OFF   | ON    | 2=0×2 <sup>4</sup> +0×2 <sup>3</sup> +0×2 <sup>2</sup> +0×2 <sup>1</sup> +1×2 <sup>0</sup> +1                                     |
| Address 3    | OFF   | OFF   | OFF   | ON    | OFF   | 3=0×2 <sup>4</sup> +0×2 <sup>3</sup> +0×2 <sup>2</sup> +1×2 <sup>1</sup> +0×2 <sup>0</sup> +1                                     |
| ..           | ..    | ..    | ..    | ..    | ..    | ..  |
| Address 16   | OFF   | ON    | ON    | ON    | ON    | 16=0×2 <sup>4</sup> +1×2 <sup>3</sup> +1×2 <sup>2</sup> +1×2 <sup>1</sup> +1×2 <sup>0</sup> +1                                    |
| ..           | ..    | ..    | ..    | ..    | ..    | ..  |
| Address 31   | ON    | ON    | ON    | ON    | OFF   | 31=1×2 <sup>4</sup> +1×2 <sup>3</sup> +1×2 <sup>2</sup> +1×2 <sup>1</sup> +0×2 <sup>0</sup> +1                                    |
| Address 32   | ON    | ON    | ON    | ON    | ON    | 32=1×2 <sup>4</sup> +1×2 <sup>3</sup> +1×2 <sup>2</sup> +1×2 <sup>1</sup> +1×2 <sup>0</sup> +1                                    |

#### Switch 8, 9: Parity bit

| Parity bit | 8   | 9   |
|------------|-----|-----|
| Even       | ON  | ON  |
| Odd        | OFF | ON  |
| None       | ON  | OFF |
| None       | OFF | OFF |

#### Switch 10: Stop bit

| Stop bit | 10  |
|----------|-----|
| 2 bit    | ON  |
| 1 bit    | OFF |

## Installation Method

### Mounting on DIN rail

#### Installation

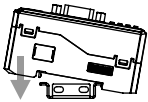

Insert bottom holder of communication converter to 35 mm width DIN rail and Push the front part of the unit to arrow direction to mount.

#### Separation

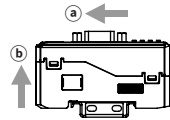

Push amplifier unit to ㉓ direction and pull the assembly part to ㉔ direction to detach.

### Connecting to amplifier unit

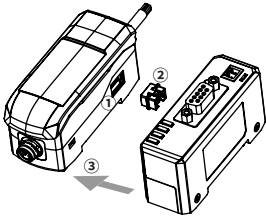

Remove the side cover (㉑) at the connecting side and connect the side (㉒) connector to the units. After mounting amplifier unit and communication unit on DIN rail, push it to arrow direction (㉓) tightly.

- In case of disconnecting, follow the upper sequence reversely.
- Check the firmware version when connecting to the amplifier unit.

### Communication system configuration

#### Distinguishing master/slave amplifier units

Comm. converter      Amplifier unit      • Max. 8 units

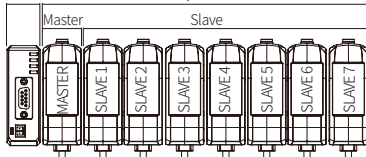

When the power cable direction is down, the amplifier at the left end is the master unit, and the channel number of slaves increases sequentially to the right. Communication converter is connected to the left side of master amplifier unit.

#### Precautions when connecting amplifier unit

- Mount on DIN rail.
- Do not supply the power when adding amplifier unit.
- Supply power to each connected amplifier unit at the same time.
- Up to 8 amplifier units can be connected, and only 1 calculation function can be performed per 1 group of mutually connected amplifiers.
- When the calculation function is activated, the setting values (SV) of the slave units are disable and the mutual interference prevention function for sensor heads is executed automatically.