

Medium voltage switchgear type W 12

rated voltage 12 kV
rated current 630 A



DRIBO, spol. s r.o.

Pražákova 36
619 00 Brno
Czech Republic

Tel.: +420 533 101 111, Fax: +420 543 216 619, E-mail: dribo@dribo.cz, Internet: <http://www.dribo.eu>

ISO 9001
ISO 14001
BUREAU VERITAS
Certification



General

The metal-encapsulated, air-insulated medium voltage switchgears, type W 12 are for universal application. They range from compact ring cable switchgears up to complex power distribution switchgears. Tailored to meet the needs of public utility networks and power supply companies in industry and municipal buildings.

These medium-voltage switchgears meet the user's specific requirements in full and ensure a satisfactory power distribution.

The W 12 standard panel types are available in three different dimensional sizes:

W 12 – 607519; w x d x h: 600 x 750 x 1900 mm,
W 12 – 757521; w x d x h: 750 x 750 x 2100 mm,
W 12 – 907521; w x d x h: 900 x 750 x 2100 mm.

They are available as individual panels or as a combined switchgear, where the equipment, panel sequence etc. can be determined by the customer.

The switch panels are type-tested in compliance with DIN VDE 0670, Part 6, including the Pehla directive No. 4.

Operating conditions

The switch panels of type W 12 are installed in closed electrical operating areas which are only to be entered by skilled personnel and appropriately instructed persons.

The equipment can be used at an altitude of up to 1000 m above sea level.

For installations above an altitude of 1000 m the rated insulating level of the switchgear must be corrected accordingly.

The switch panels are designed for use under normal operating conditions in compliance with the standard DIN VDE 0670, Part 1000(IEC 62271).

Technical standards

The design of the air-insulated switch panels corresponds to the specifications of the DIN VDE 0670, Part 6. The resistance to accidental arcs of the switch panels has been determined at 16 kA and 20 kA; 1 s, by an independent testing institute.

The installed switchgear equipment is designed in compliance with DIN VDE 0670, Part 1000 (IEC 62271).

Technical data

rated voltage	12 kV
rated frequency	50 Hz
rated lightning impulse withstand voltage	75 kV
rated short-time withstand voltage	28 kV
rated short-circuit duration	1 s
rated current – panels with circuit breaker V12-630-25 KUF	630 A
rated current – panels with load disconnecter H 22	630 A
rated short-time current – panels with circuit breaker V12-630-25 KUF	25 kA
rated short-time current – panels with load disconnecter H 22	20 kA
rated peak current – panels with circuit breaker V12-630-25 KUF	63 kA
rated peak current – panels with load disconnecter H 22	50 kA
degree of protection	IP 3X

Description of the W 12 switch panels

Design

The air-insulated medium-voltage switch panels of type W 12 with a panel width of 600 mm, 750 mm and 900 mm are metal-encapsulated. The switch panel frame is made of a screwed, hot-galvanized composite structure. The front of the switch panels has a single-wing door of steel sheet with door hinge optionally on the right or left. A window of compound glass is inserted in the door.

The cover in front of the bus bar compartment is either screwed on or designed as a door for the relay box positioned behind it.

Each switch panel has a screwed on rear panel of galvanized sheet metal. Connecting cables are conducted into the switch panels from below and are mounted on cross rails.

The doors and covers of the switchgear are painted in structural paint (available in different colours according to the customer's request).

Equipment

The switch panels of type W 12 are available in the following versions:

- Cable switch panel **WK 12**
- Transformer feeder panel **WT 12**
- Measuring switch panel **WM 12**
- Bus sectionaliser panel **WÜ 12**
- Circuit-breaker panel **WL 12**

All switch panels are partitioned off from panel to panel, in the bus bar area, by means of fibrous-glass reinforced plastic plates with lead-in openings.

Pressure relief can be in upward or downward direction.

Switch panels equipped with load-break switches can optionally be fitted with an earthing switch as well. Integrated in the circuit-breaker panel, type

WL 12, there is also a bus disconnecter. It is also possible to equip these panels with a set of current transformers and voltage transformers as well as with an earthing switch.

The optional interlocking of the equipment practically rules out any form of incorrect operation. All built-in switchgear equipment can be operated manually or via motor-operated mechanisms when the panel door is closed.

The product program is completed by special measuring panels which are fitted with current and voltage transformers. Earthing switches or spherical fixed points are available for earthing and short-circuiting. An insulating protective plate can be inserted when the panel door is closed. It is possible to install appropriate surge voltage protectors in the panel, if required.

W 12 switch panels

- optional
- not possible
- * not possible with current or voltage transformer

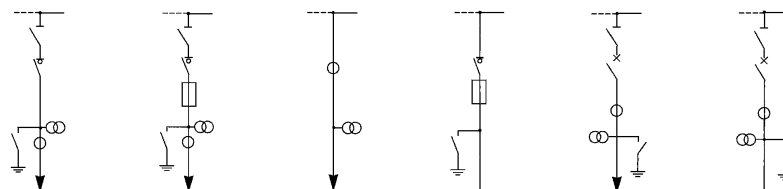

	WK Cable panel	WT Transformer feeder panel	WM Measuring panel	WÜ Bus section. panel	WL Circuit breaker panel	WÜL Circ. br. bus sect. panel
Switch panels W 12 – 607519						
Disconnecter	•*	•*	-	-	•	•
Load disconnecter / circuit breaker	H 22 EA / EK	H 22 SEA	-	H 22 EK / EA / SEA	V 12.. KUF	V 12.. KUF
Earthing switch	•	•	•	•	•	-
Current transformer	•	•	•	-	•	•
Voltage transformer	•	•	•	-	-	-
Switch panels W 12 – 757521, W 12 – 907521						
Disconnecter	-	-	-	-	•	•
Load disconnecter / circuit breaker	H 22 EA / EK	H 22 SEA	-	H 22 EK / EA / SEA	V 12.. KUF	V 12.. KUF
Earthing switch	•	•	-	•	•	-
Current transformer	•	•	•	-	•	•
Voltage transformer	•	•	•	-	•	-

Weights

Panel type	Description	Weight [kg]		
		W 12 - 607519	W 12 - 757521	W 12 - 907521
WK 12	cable switch panel	245	275	290
WT 12	transformer feeder panel	275	305	320
WÜ 12	bus sectionaliser panel	300	330	345
WM 12	measuring switch panel	240	270	285
WL 12	circuit-breaker panel	350	380	395

Auxiliary equipment

- insulating protective plate in compliance with DIN VDE 0681 part 8
- panel illumination, floor coverings
- capacitive voltage testing system in compliance with DIN VDE 0682 part 415, short-circuit indicators
- additional locking systems with profile cylinder and lockable operating mechanisms

Type W 12 – 607519 switch panels

Positions:

- 1 Pressure relief plate
- 2 Relay box
- 3 Bus terminal
- 4 Switch-disconnector H 22
- 5 Withdraw able plate
- 6 Current transformer
- 7 Voltage transformer
- 8 Circuit breaker
- 9 Position indicator and actuation of load-break switch
- 10 Position indicator and actuation of disconnecting switch
- 11 Position indicator and actuation of earthing switch
- 12 Earthing switch
- 13 Disconnecting switch
- 14 HV-HBC fuse
- 15 Cable terminal

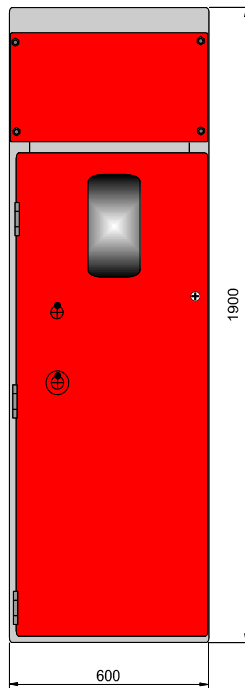

Type W 12 – 607519 switch panel – front view

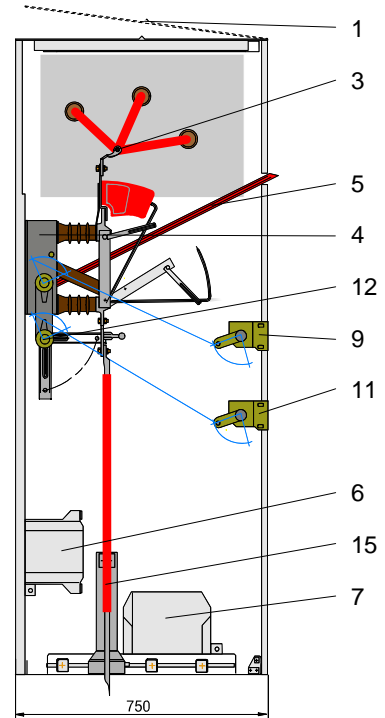

Cable panel with H22 EA/EK load discon. also possible with current and voltage transf. – side view

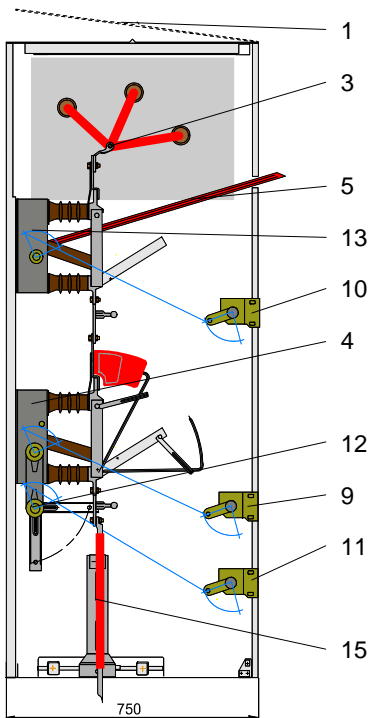

Cable panel with H22 EA/EK load disconnector and disconnector – side view

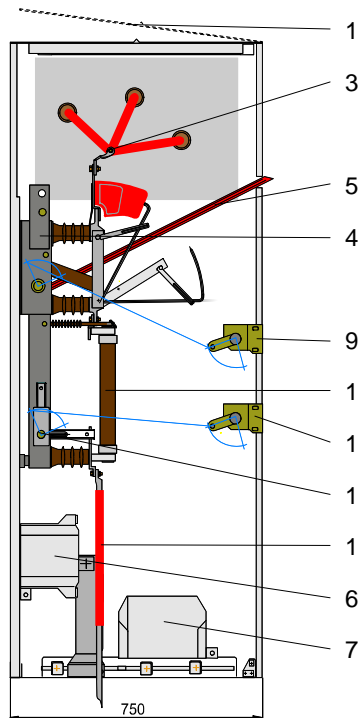

Transformer feeder panel with H22 SEA load disconnector, also possible with current and voltage transformer – side view

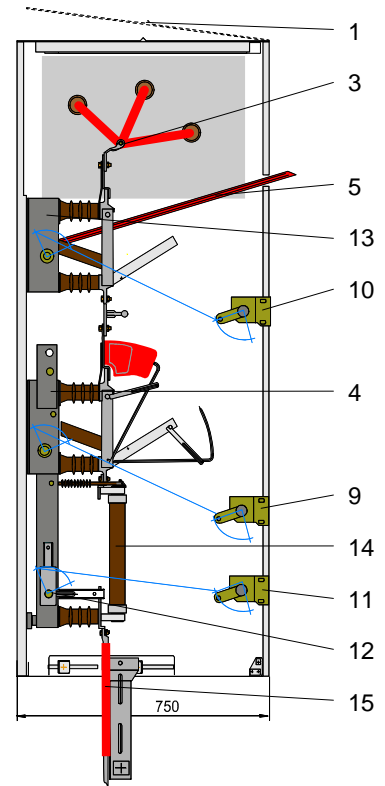

Transformer feeder panel with H22 SEA load disconnector and disconnector – side view

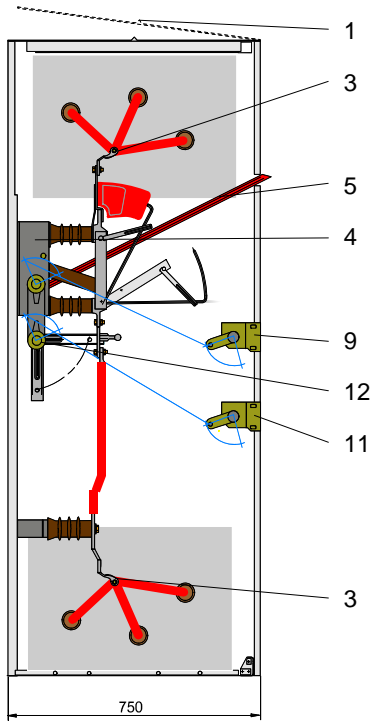

Bus sectionaliser panel with H 22 EA / EK load disconnectors – side view

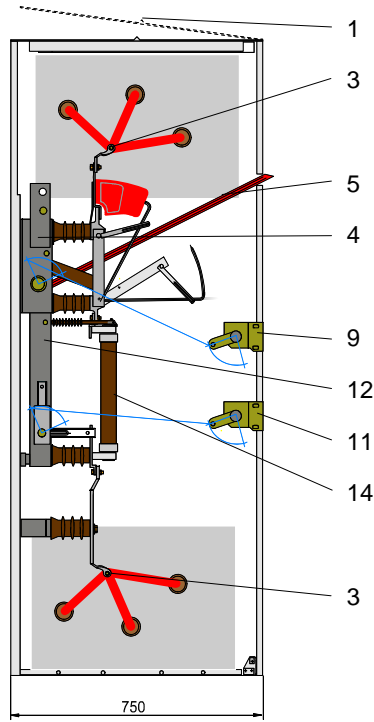

Bus sectionaliser panel with H 22 SEA load disconnectors – side view

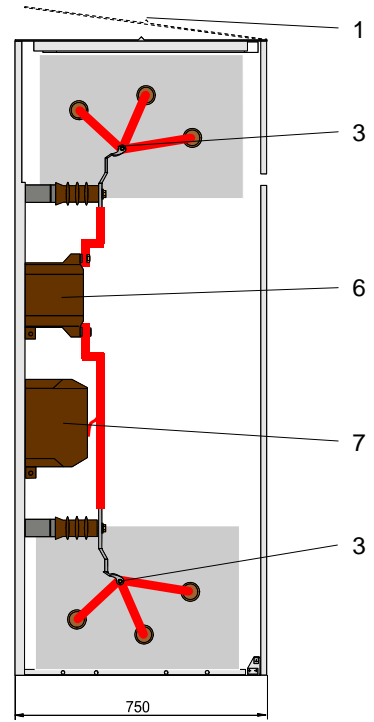

Measuring panel with current and voltage transformers – side view

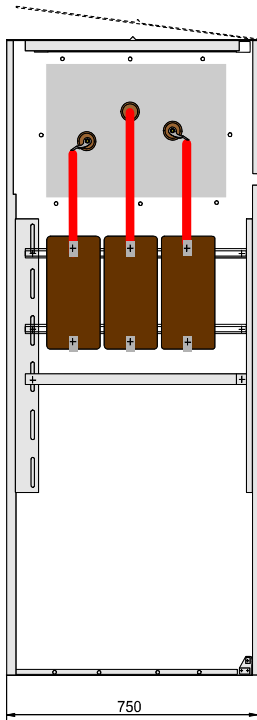

Measuring panel in longitudinal rails with current and voltage transformers – side and front view

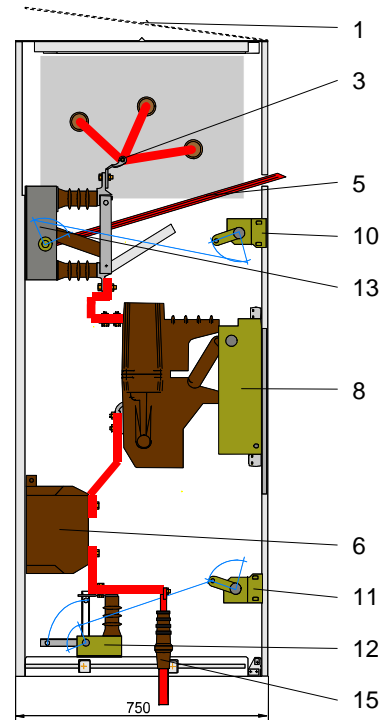
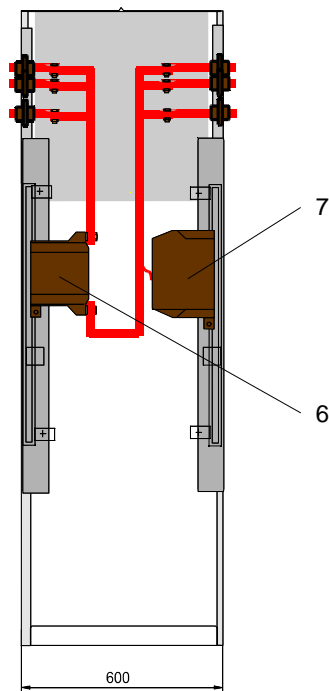

Circuit-breaker panel with circuit breaker and disconnector – side view

Type W 12 – 757521 and W 12 – 907521 switch panels

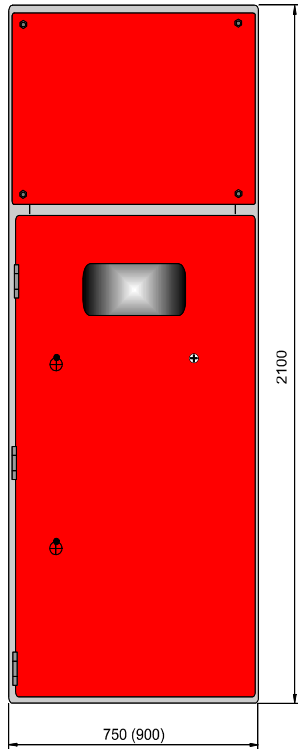

Type W 12 – 757521 and W 12 – 907521 switch panel – front view

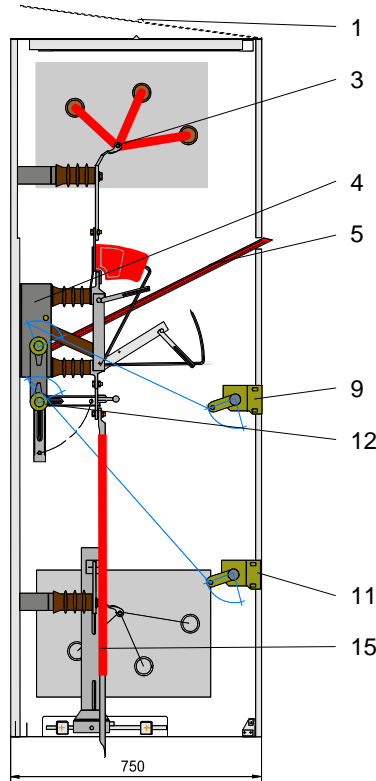

Cable panel (bus sectionaliser panel) with H 22 EK / EA load disconnectors – side view

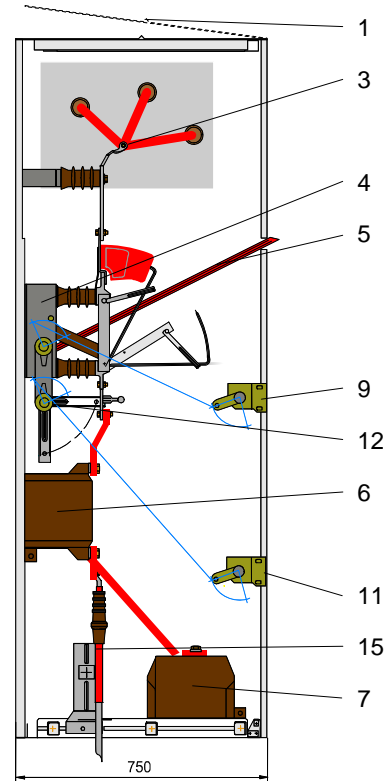

Cable panel with H 22 EK / EA load disconnectors, current and voltage transformer – side view

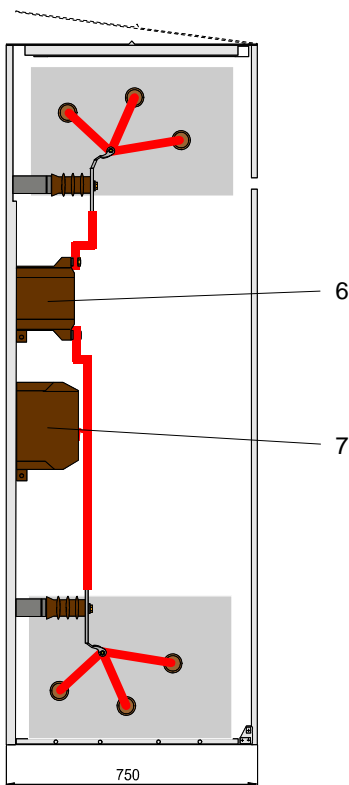

Measuring panel with current and voltage transformer – side view

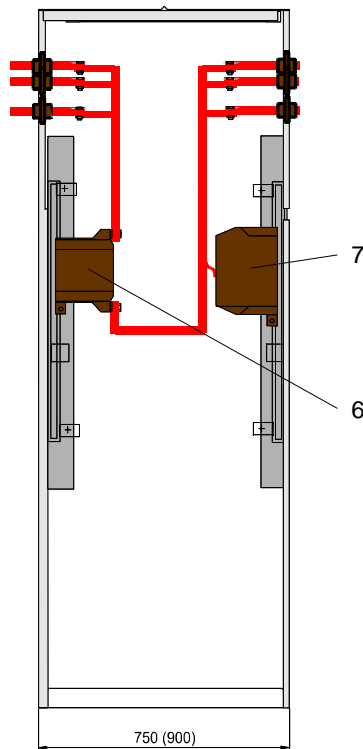

Measuring panel in longitudinal rails with current and voltage transformer – side view

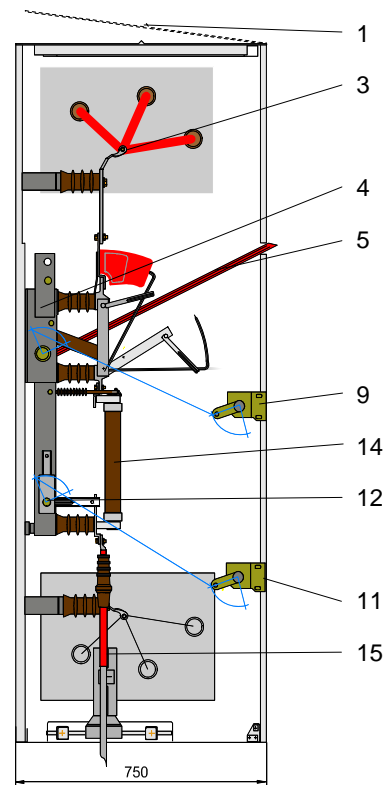

Transformer feeder panel (bus sectionaliser panel) with H 22 SEA load disconnectors – side view

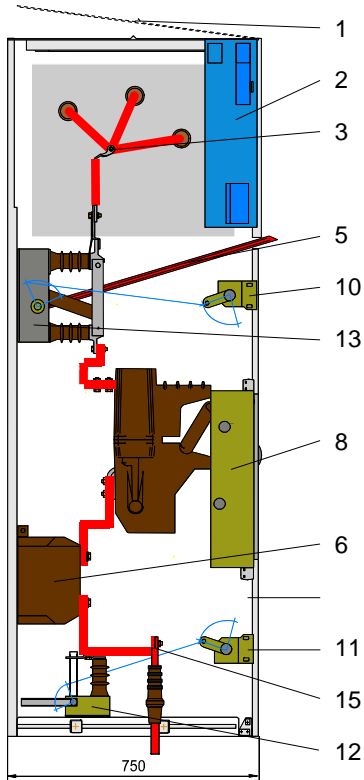

Circuit-breaker (V12-630-25 KUF)
panel with current transformer –
side view

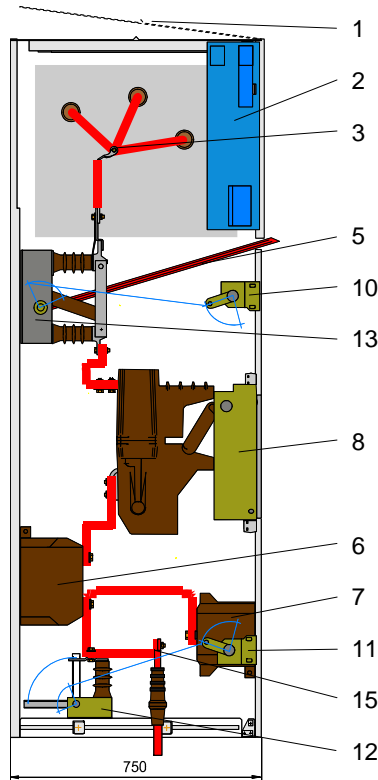

Circuit-breaker (V12-630-25 F)
panel with current and voltage
transformer – side view

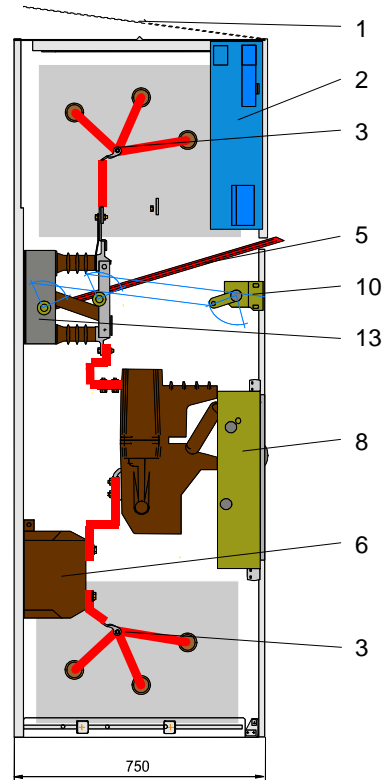

Circuit-breaker (V12-630-25 KUF)
panel (bus sectionaliser panel),
also possible with current
transformer – side view