

1E EGJ Junction Boxes

Cl. I, Div. 1 and 2, Group D
 Cl. II, Div. 1, Groups E, F, G
 Cl. II, Div. 2, Groups F, G
 Cl. III

Explosionproof
 Dust-Ignitionproof

Applications:

- The EGJ series junction boxes are designed for flush installation in the concrete pump island of gasoline service stations

Features:

- Cover sealed with "O" ring gasket to make unit raintight
- Cover recess will accept tool used to open cover of gasoline storage tank
- Two drilled and tapped conduit entrances on the bottom and six on the sides
- Plugs are provided for the two bottom entrances and four of the side entrances for choice of conduit arrangement
- ES sealing hubs thread into the bottom to seal the mainfeed
- Caulking compound supplied for filling space between cover flange and body rim to prevent accumulation of water, dirt and ice. Compound remains pliable and is easily removed

Unused conduit entrances must be securely plugged with type PLG threaded pipe plugs to maintain flametight conditions (see section 5F). See illustration for method of constructing seals.

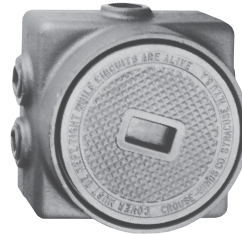

EGJ421



EGJ422

Ordering Information

Body Size		Drilled and Tapped Conduit Entrances				Replacement Cover	
Length and Width	Depth	No. of Hubs		Size	Cat. #	Cat. #	Cat. #
		Side	Back				
5 3/4	4 3/16	6	2	3/4	EGJ421	EGJ:10706L	
7	5 9/32	6	2	3/4	EGJ422	EGJ:10705L	

Sealing Hubs (order separately)

For	No.	Female Hub Size	Cat. #
EGJ421	2	1	ES53
EGJ422	2	1 1/4	ES64



Typical Installation

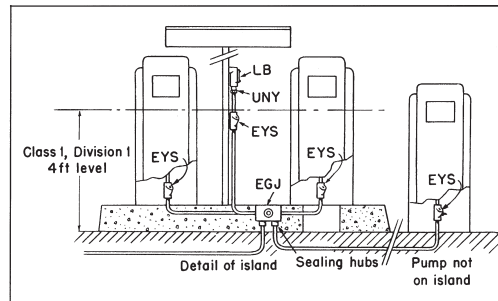

How to construct seal

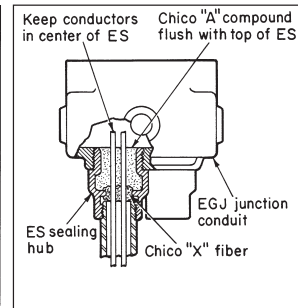

Certifications and Compliances:

- NEC/CEC
 - Class I, Division 1 and 2, Group D
 - Class II, Division 1, Groups E, F, G
 - Class II, Division 2, Groups F, G
 - Class III
- UL Standard: 1203
- CSA Standard: C22.2 No. 30

Standard Materials:

- Bodies – Feraloy® iron alloy
- Covers – copper-free aluminum

Standard Finishes:

- Feraloy iron alloy – electrogalvanized and aluminum acrylic paint
- Copper-free aluminum – natural

Dimensions In Inches:

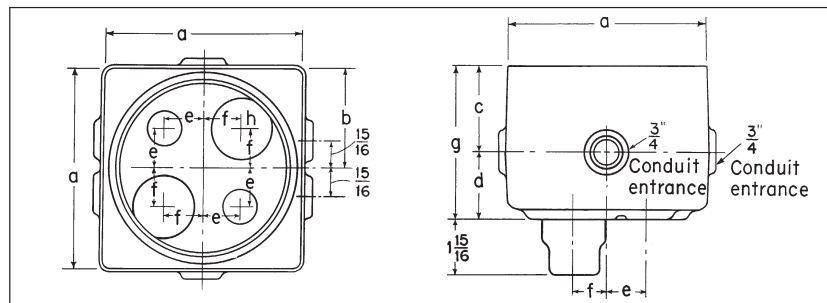

Cat. #	a	b	c	d	e	f	g	h
EGJ421	5 3/4	2 7/8	2 7/16	1 3/4	1 1/8	1 5/16	4 3/16	1 1/2" entry
EGJ422	7	3 1/2	3	2 9/32	1 3/8	1 7/8	5 9/32	2" entry

For conduit liner ordering information, see page 860.

Both the EGJ421 and EGJ422 junction boxes have 4 drilled and tapped conduit entrances in the back (see drawing above). The 2 larger diameter holes are for the ES Sealing Hubs and there are provisions for 2 smaller diameter conduit entrances.